

USER MANUAL

SMARTEC Lead Free Brass Electronic Sensor Taps and Sensor Kits

- **STSLF1000(M, B, BM)** - Lead Free DZR Brass Hob Mounted Right Angle Electronic Tap w/ Infrared Sensor
- **STSLF2500(M, B, BM)** - Lead Free DZR Brass Wall Mounted Electronic Tap w/ Infrared Sensor
- **STS3500(M, B, BM)** - Zero Lead Stainless Steel 304 Wall Mounted Electronic Sensor Plate w/ No Spout Infrared Sensor

M: Mains Powered

B: Proprietary Battery Powered

BM: Battery & Mains Powered



gentecaustralia.com.au

USER MANUAL

Table of Contents

Scope of Use	2
Technical Information	3
Product Images & Technical Drawings	4
Exploded Drawings	7
Installation Steps	7
Remote Operation	12
General Connection	16
Cleaning & Maintenance	18
Troubleshooting	19
Water Quality	20
Responsibly Sourced	21

Scope of Use

Installation of all products should adhere to the manufacturer's guidelines, as well as comply with PCA, AS/NZS3500 standards, and any other relevant regulatory provisions. This product range complies with the Lead Free requirements of the National Construction Code Volume Three.

- **Installation:** Refer to the installation instructions included within this manual
- **Water quality:** In line strainer (supplied with control box) must be installed to ensure water quality
- **Suitable for indoor use only**
- **Temperature recommendation:**
 - Single temperature up to 50°C
 - Minimum temperature: 5°C
- **Power voltage:** 6 V AC / DC (battery integrated)
- **Sensor:** Infrared sensor
- **Mounting:** Wall, bench or in line installation

Technical Information

Electronic Sensor Taps and Sensor Plates

Material	<ul style="list-style-type: none"> · Electronic Sensor Taps: Lead Free DZR Brass · Electronic Sensor Plate: Zero Lead Stainless Steel 304
Cartridge	Solenoid Valve
Cartridge Size	15 mm
Inlet	<ul style="list-style-type: none"> · Electronic Sensor Taps: 15mm Female Flexible Connections · Electronic Sensor Plate: 15mm Male
Flow Style	Electronic Sensor Taps: Laminar Flow
Run Time	<ul style="list-style-type: none"> · Electronic Sensor Taps: 2 seconds (auto on / off) · Electronic Sensor Plate: 15 seconds Wave on / Wave off
Working Pressure	50kPa-500kPa
Recommended Working Pressure	350kPa
Working Temperature	5°C - 50°C
Finish / Colour	<ul style="list-style-type: none"> · Electronic Sensor Taps: Chrome Plated · Electronic Sensor Plate: Brushed

USER MANUAL

Product Images & Technical Drawings

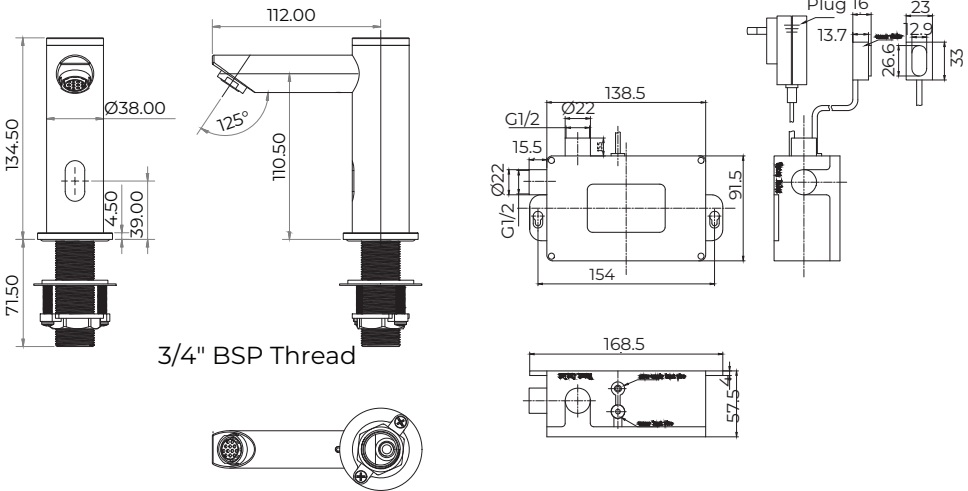

3/4" BSP Thread

STSLF1000

BM - Lead Free DZR Brass Hob Mounted Right Angle Electronic Tap w/ Infrared Sensor Battery & Mains Powered

B - Lead Free DZR Brass Hob Mounted Right Angle Electronic Tap w/ Infrared Sensor Proprietary Battery Powered

M - Lead Free DZR Brass Hob Mounted Right Angle Electronic Tap w/ Infrared Sensor Mains Powered

USER MANUAL

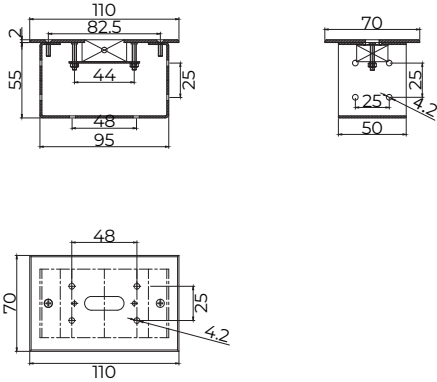

STS3500

BM - Zero Lead Stainless Steel 304 Wall Mounted Electronic Sensor Plate w/ No Spout Infrared Sensor Battery & Mains Powered

B - Zero Lead Stainless Steel 304 Wall Mounted Electronic Sensor Plate w/ No Spout Infrared Sensor Proprietary Battery Powered

M - Zero Lead Stainless Steel 304 Wall Mounted Electronic Sensor Plate w/ No Spout Infrared Sensor Mains Powered

Note: Dimensions are provided as a guide and are subject to manufacturing tolerances.

Exploded Drawings

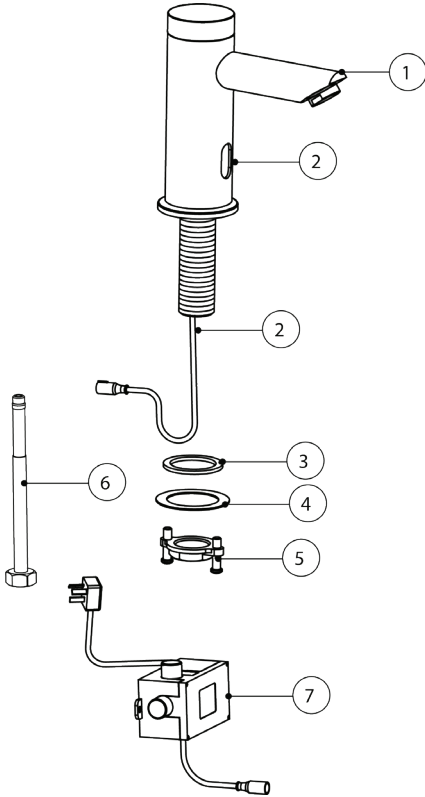

Item#	Description	Spare Parts
1	Tap Body	<input type="checkbox"/>
2	Sensor* Preventative Maintenance	<input checked="" type="checkbox"/>
3	Foam Washer	<input type="checkbox"/>
4	Metal Washer	<input type="checkbox"/>
5	Back Nut	<input type="checkbox"/>
6	Flexible Hose	<input type="checkbox"/>
7	Solenoid Box	<input checked="" type="checkbox"/>

*Note: To minimise product downtime, we recommend that you regularly check these items.

Installation Steps

BEFORE SETUP, MAKE SURE:

- Installation must be done by a qualified and licenced plumber and adhere to AS/NZS3500 and manufacturer's recommendations.
- Lines must be flushed before installation and the strainer provided must be installed to prevent debris damaging the cartridges.
- Avoid use on shiny / reflective surfaces such as aluminium, glass or similar. Reflection may cause sensitivity issues with the sensor.

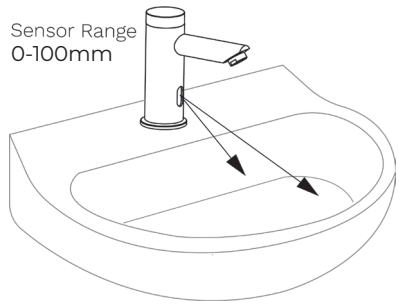

Reflective surfaces could cause nuisance triggering and activate the sensor when installed out of the suggested minimum clearance. See images below:

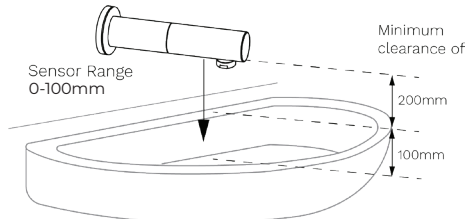

If the tap will sometimes affect the operation of the sensor or if in the event the tap is continuously running, we recommend to adjust the sensor back so it is not as strong, please refer to the remote set up.

USER MANUAL

STSLF1000 (M, B, BM) INSTALLATION STEPS

Step 1. Flush the new pipe prior to installation.

Step 2. Remove rubber seal, fixing plate and fixing nut.

Step 3. Screw in the flexible hose.

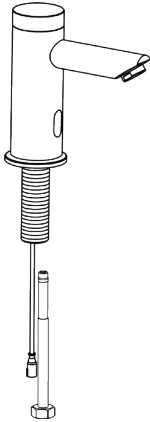

Step 4. Place the Flange, and the tap unit in the pre-punched hole (30mm to 35mm) in the counter top.

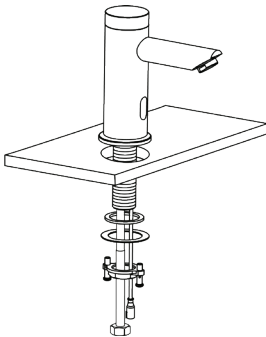

Step 5. From underneath the sink or basin, fix rubber seal, fixing plate and fixing nut with a spanner. Make sure the screws are well tightened to the counter top.

Step 6. Attach flexi hose to the water outlet on the solenoid and screw the solenoid box to the wall.

Step 7. Plug in the sensor cable to the solenoid box.

Step 8. Attach flexi hose from water supply to the inlet on the solenoid box.

Step 9. Plug in solenoid box to mains power supply.

Step 10. Place hand in front of sensor to activate and verify operation.

Note: Make sure to switch on power first and then the water supply. Check for leaks.

STSLF2500 (M, B, BM) INSTALLATION STEPS

- Step 1.** Drill a hole 30mm in diameter. Drill two more holes, 25mm from the centre of the large hole and 6mm in diameter on either side.

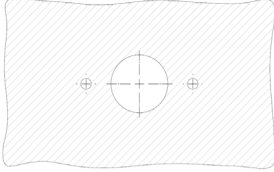

- Step 2.** Screw the thread onto the flexi-hose and feed it through the wall.

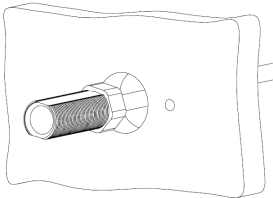

- Step 3.** Secure the back nut onto the thread from behind the wall. Screw the nut far enough that the thread is flush with the front of the finished wall while the nut is touching the back face of the wall. Place a 15mm inner diameter conduit behind the wall to feed the cables of the tap through.

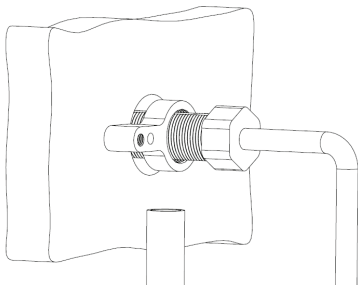

- Step 4.** Feed the cable through the hole in the wall and into the conduit.

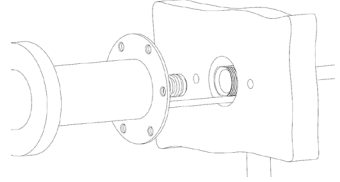

- Step 5.** Push the tap onto the thread and secure it in place with the long button screws. Ensure that the screws pass through the 6mm holes and through the fixing nut.

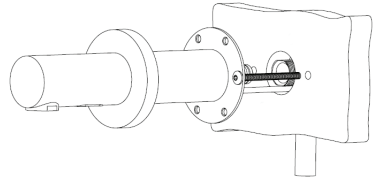

- Step 6.** Secure the fixing plate to the wall using the wall screws. If required, wall plugs can be used to ensure the screws stay fixed.

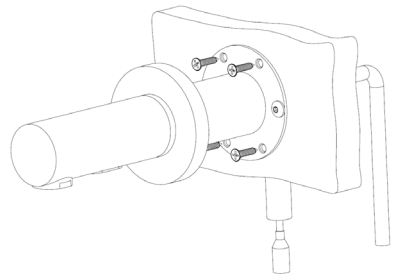

- Step 7.** Push the flange over the cover plate.

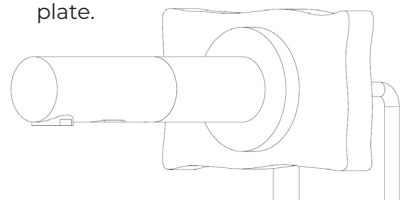

USER MANUAL

Push Fit Method

Step 1. Remove the back nut from the threaded tail (not required for this installation).

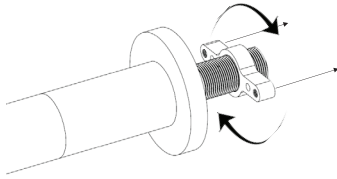

Step 2. Allow a 15mm (minimum) conduit for easy installation of the sensor wires. Individual installation may vary.

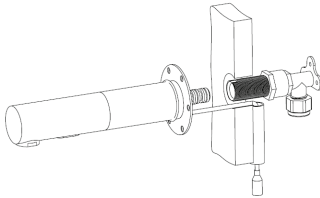

Step 3. Apply adequate thread tape and screw on the threaded piece into the female plumbing fitting in the wall. Use the 2 flats to tighten with correct spanner.

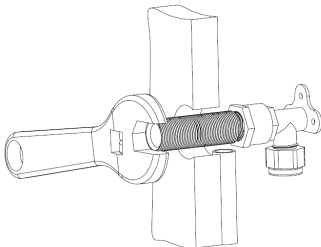

Step 4. Feed the sensor wires through the conduit and push the tap body through the threaded piece.

Step 5. Use the spout flange to mark out the 6 mounting screw holes.

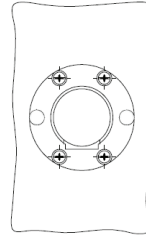

Step 6. Fix the screws and tighten.

Step 7. Slide over the cover flange and press it against the wall firmly.

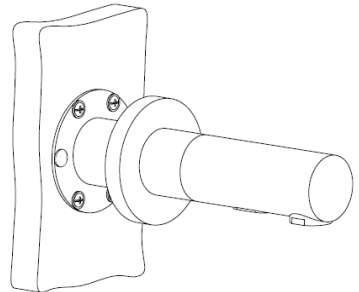

Important Information

Switch power on solenoid box first before turning on water supply.

STS3500 (M, B, BM) INSTALLATION STEPS

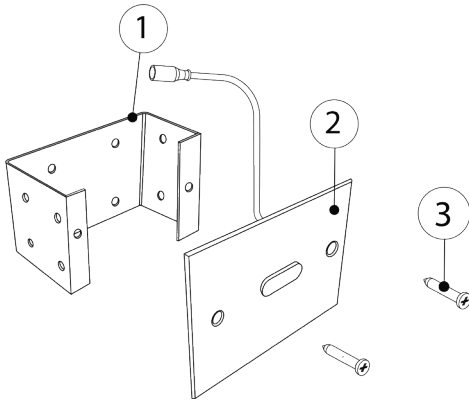

Wall Bracket Installation

Step 1. Allow a straight line cut 96mm (width) x 50mm (height) in the wall 70mm to 110mm deep. Screw the bracket (1) to the wall and tighten. **Do not compress or expand the bracket and ensure the screw holes align with the sensor plate (2).**

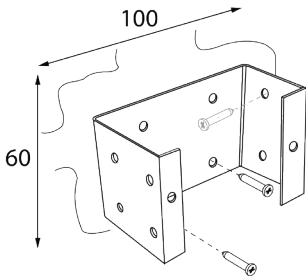

Step 2. Connect the sensor cable from the sensor plate (2) to the solenoid wire. **Use a conduit to feed the wire up to the sensor plate.**

Step 3. Install the sensor plate (2) by tightening the screws provided (3) equally. The screws have up to 7mm adjustment.

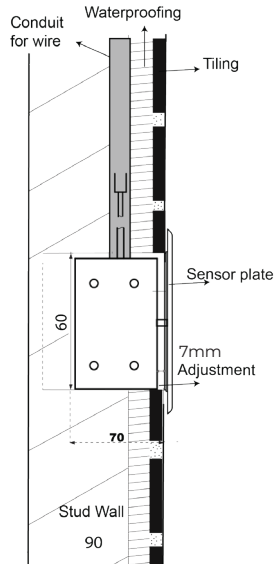
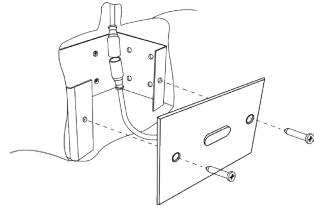

Important Information



Plug in the power adaptor first and test electronics before turning on the water supply.

USER MANUAL

Remote Operation

BEFORE SETUP, MAKE SURE:

- To use good quality AAA batteries. Fit the batteries into the remote and replace the cover.
- Ensure that the LED light on the control blinks after pressing any button.
- Direct the front of the remote at the sensor within 50-100mm and press relevant button to change the setting to suit your desired need.
- Every time you press a button on the Remote controller, the indicator LED light turns on, this indicates you have made a change. Wait at least 2 sec between every adjustment.
- Default Settings
Automatic ON/OFF, 2 Sec Run Time
Wave ON/OFF, 15 Sec Run Time

Functions	Grey Remote	Black Remote
STS9006 Adjusting Controller Set		
Product Type	Sensor Range and Time Adjustment. *Sensor Adjustment range 0mm up to 120mm	Selection Mode
Button 1	Increase the sensor distance (1cm-2cm increments)	Activate Automatic ON (2sec run time)
Button 2	Decrease the sensor distance (1cm-2cm increments). Ensure Automatic mode (default) is activated before changing the run timing	Activate Wave ON (15 sec run time). Ensure Wave mode is activated before changing the time between Hygiene fFlushes
Button 3	Increase the run timing	Increase time between Hygiene Flush
Button 4	Decrease the run timing	Decrease time between Hygiene Flush
Button 5	Deactivate Sensor	Hygiene Flush on/off

GREY REMOTE

NOTE: For each of the following, “ . ” represents a light signal of short duration, while “ – ” represents a light signal of noticeably longer duration. A long space “ - ” represents a pause.

Button 1: Increases Sensor Distance

. : Sensor distance has successfully increased.
When at the maximum sensor distance, the sensor will flash based on the current run timing and Hygiene Flush timings.



Button 2: Decreases Sensor Distance

. : Sensor distance has successfully decreased.
When at the minimum sensor distance, the sensor will flash based on the current run timing and Hygiene Flush timings.

Button 3: Increases the run timing.

Button 4: Decreases the run timing.

NOTE: Either Automatic or Wave mode must be selected to alter the run timing. If Hygiene Flush mode is activated, then the sensor will flash additionally based on the Flush mode's setting. Please refer to the Black Remote guide for these flashes.

Setting Level	Corresponding Run Time	Flash Sequence
Setting 1	2s	. .
Setting 2	5s
Setting 3	10s
Setting 4	15s
Setting 5	20s
Setting 6	25s
Setting 7	30s

Button 5: Deactivates Sensor

When deactivating, it will flash based on the current run timing and Hygiene Flush timings.

USER MANUAL

BLACK REMOTE

Button 1: Activates sensor in Automatic mode.

Can switch from Wave mode.

Sensor will flash based on the run timing and Hygiene Flush.



Button 2: Activates sensor in Wave mode. Can switch from Automatic mode.

Sensor will flash based on the run timing and Hygiene Flush.

Button 3: Increases the time between Hygiene Flushes.

Button 4: Decreases the time between Hygiene Flushes.

NOTE: If Hygiene Flush is deactivated, the sensor will only flash based on the run timing. This will not alter the timing of the mode. With the Hygiene Flush mode activated, the sensor will flash based on run timing, followed by the setting for the time between Hygiene Flushes. If at the maximum or minimum run time and a button is pressed to select a setting that does not exist, then the sensor will flash quickly based on the run timing setting. If choosing a setting that exists, the sensor will flash once, followed by a pause, and then will complete its flashes based on the run timing.

The flashes below are only indicative of the setting for the time between Hygiene Flushes.

Setting Level	Corresponding Run Time	Flash Sequence
Setting 1	6 Hours	—
Setting 2	12 Hours	— —
Setting 3	24 Hours	— — —
Setting 4	48 Hours	— — — —

Button 5: Activates/Deactivates Hygiene Flushes

When deactivating, it will flash based on the current run timing. When activating, it will flash based on the current run timing, and then the current Hygiene Flush timing.

AUTOMATIC ON/OFF

When hands are in the sensor's range, program turns ON. Removing hands from the sensor's range will switch the sensor OFF. See Figure 1

Default is for Sensor to switch OFF after 2 seconds RUN; however this is adjustable with the Grey Remote Controller 1.

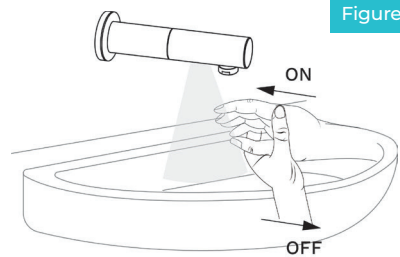

Figure 1

WAVE ON/OFF

Waving hands within the sensors range switches the program to ON.

Waving hands again within the sensors range will switch the sensor to OFF. See Figure 2

Pre-set run time is 15 seconds run, however this is adjustable using the Grey Remote Controller 1.

Run Time Adjustment

Before changing the run time, Select the Mode option with the Black Remote Controller. Then, using the Grey Remote Controller, Button 3 (increase) and Button 4 (decrease) the run time.

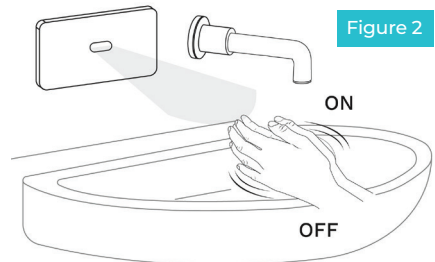

Figure 2

HYGIENE FLUSH

- Hygiene Flush is not activated by Default.
- Hygiene Flush can be activated by Black Remote STS9005B2.
- Hygiene Fush run time is locked at 40 second run time. This run time cannot be adjusted.

Note:

To change the time between Hygiene Fushes (6 hours, 12 hours, 24 hours, 48 hours), use the Black Remote Controller 2 .
To INCREASE the time between Hygiene Flush, use Button 3.
To DECREASE the time between Hygiene Flushes, use Button 4 .

USER MANUAL

General Connection

FOR STSLF1000 (M, B, BM), STSLF2500 (M, B, BM)

Screw the solenoid box to the wall by using the screws provided.

Ensure there is sufficient space between the wall and the taps mounting point for easier installation.

BM: Battery and Mains Operated

B: Battery Operated

M: Mains Operated

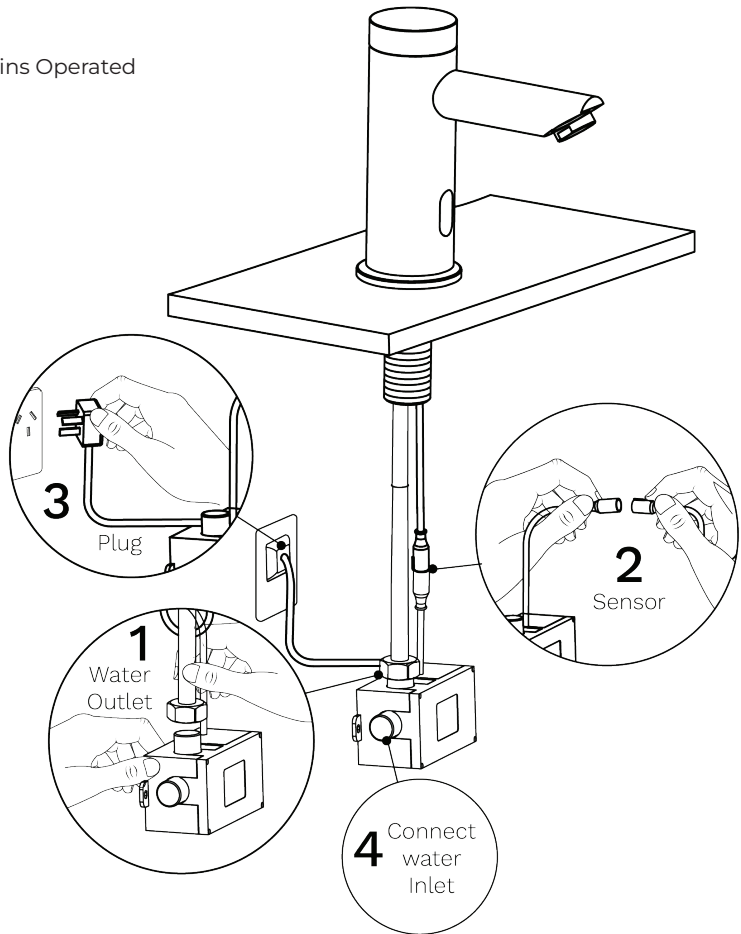

Please refer to the diagram on page 16.

- Step 1. Connect the tap flexible hose to the solenoid box outlet. Make sure the connections are firm and in the right place.
- Step 2. Connect the sensor cable from the tap to the solenoid box.
- Step 3. Plug in the solenoid box power supply.
- Step 4. Connect the water supply to the solenoid box inlet.

When using the unit for first time

- Make sure to turn on the power first and then the water.
- Lines must be flushed before installation.

Follow the installation guide.

Instruction For Use

- When the unit is powered on, water should flow immediately when you put your hands within range of the sensor. When you remove your hands out of range, water should stop within 2 seconds. The maximum duration of continuous flow is 1 minute.
- The default factory set distance is 5-10cms.

Battery Change

- Step 1. The indicator light in the sensor will flicker 3 times per second to indicate the batteries are at the end of their useful life. At this stage the unit will no longer operate in battery mode.
- Step 2. If you have plugged in the mains, disconnect the power and open the cover of the control box, open the battery holder, remove the batteries and replace all batteries with new ones.
- Step 3. Please make sure you install the batteries in the correct direction, the + and - side are indicated in the battery holder.
- Step 4. Close the battery holder, place into the control box and screw the lid closed.

USER MANUAL

Cleaning & Maintenance

To minimise downtime and maximise the functional life of the product, GENTEC recommends servicing your product at least every 12 months, under heavy use may need to be checked and serviced more often.

- The product must be handled carefully to avoid causing any physical damage.
- Use the product at least once every week to ensure all parts are kept lubricated and functioning properly.
- Service the product at least once a year to avoid any product failures - The service timeline provided is based on normal use. More frequent servicing may be required for heavy usage.
- A working pressure of 350kPa is highly recommended to ensure the maximum up-time of the product.
- Regularly clean the product with a soft cloth with warm soapy water, wash off with warm water and dry off with a soft dry cloth, paying attention to removing the dust and contamination in the bends and joints is highly recommended.
- Abrasives, hard clothes, strong acids, and bleaches must be avoided when cleaning all GENTEC products.
- Installation must be completed by a qualified and licenced plumber and adhere to AS/NZS3500 and manufacturer's recommendations.

Parts	Product Name
STS10CX2SO	SMARTEC Solenoid only
STS10CX2	SMARTEC Control Box
STS9003	SMARTEC infrared sensor for taps

Troubleshooting

Problem	Cause	How to Fix
Tap is not shutting off	<ul style="list-style-type: none"> • Debris • Power connections 	<ul style="list-style-type: none"> • Is the power connected • Did you turn the power on then the water, if you didn't do that, then start the process again, turn the power and water off • Have you flushed the water line for a minimum of 1 minute before connecting the water • Have you installed the strainer and flow controller if provided • If debris is in the solenoid, then it must be cleaned out and if it's still a problem, it must be replaced, debris may have had affected the seat causing the item to leak • Have you checked to make sure the pressure is to manufacturer's recommendations and in line with the plumbing code • Ensure there is power from the power point
No power	<ul style="list-style-type: none"> • Electricity not on 	<ul style="list-style-type: none"> • Check power is connected and on • Ensure the lights come on the sensor, if not then power is not connected and or not plugged in correctly • Make sure the lights come on the sensor • If light don't come on the sensor, it could be power related • If all the above is ok, it may require a new sensor
Run cycle not right	<ul style="list-style-type: none"> • Need to be re-programmed 	<ul style="list-style-type: none"> • Product is factory set to run on when your hands have activated the sensor • Changing programs, have you got a remote, if not, then you need a remote and the instructions to adjust the program to suit your needs

USER MANUAL

Problem	Cause	How to Fix
Issue with water flow	<ul style="list-style-type: none"> • Not enough water • Too much / little water 	<ul style="list-style-type: none"> • Check for blockage • Is the isolating valve fully open • Have got these in a bank, if so, is the inlet pipes been sized correctly • Has the flow control been installed • Pressure is too high, max inlet water pressure is 500kPa but manufacturer's recommended pressure is 350kPa • If the flexi hose is used, ensure it's not kinked/twisted
How often do I need to service my tap	<ul style="list-style-type: none"> • Prevent product failure 	<ul style="list-style-type: none"> • Service and maintenance of the main operating parts is recommended as this will prolong the life of the product

Water Quality

Maximum chloride Cl- level Guidelines in plumbing systems

	Cold Water	Hot Water
Grade 304L	200	50
Grade 316L	1000	250

When materials may be used in either hot or cold water lines, the guidelines for hot water should be used.

Within these guidelines at ambient temperatures and provided the pH >~6, any negative effect to stainless steel will be unlikely.

Note: Chlorides in water - where the density of the solvent (water) is 1 (which it is to within 0.1% at ambient temperatures), then mg/L = ppm.

For brass products, please ensure the chlorine and chloramines levels are not more than 0.4 ppm.

Please ensure that the water quality supplied to the fixtures meets safe drinking standards to prevent potential staining of the product.

Chlorine guidelines (not to be confused with chloride)

- 304L suitable for chlorine levels up to 2ppm.
- 316L suitable for chlorine levels up to 5ppm.
- Short term dosing, for example 25-50ppm, for sterilisation purposes of 24-48 hours acceptable if effectively flushed through afterwards.
- Sterilisation is essential during commissioning of potable water systems.

Reference: <https://www.assda.asn.au/component/content/article?id=271:chlorine-and-chloride--same-element,-very-different-effect>

Responsibly Sourced



Reduce Carbon Footprint

GENTEC is rejuvenating the product- no power, less maintenance and longer life.

Rejuvenation Program

To learn more about the rejuvenation program, please contact our customer service at info@gentecaustralia.com.au for more information.

Ethically and Environmentally Sourced

Please refer to GENTEC Business Ethics & Ethical Sourcing Policy at <https://gentecaustralia.com.au/terms-and-conditions/>



A: Unit 6, 20-28 Ricketty St,
Mascot, Sydney, NSW 2020

E: info@gentecaustralia.com.au

P: +612 9319 4422

F: +612 8088 7635

Gentec products come with a Manufacturer's Warranty. To ensure the validity of this warranty, Gentec products must be installed following the provided installation instructions and adhering to AS 3500, NCC Volume Three, relevant Australian Standards, and any local authority requirements applicable to the product. Additionally, water and electrical supply conditions must meet the appropriate national and/or state standards. Non-compliance with these provisions may void the warranty and impact product performance.

Note: The information provided is only a guide, actual product may differ. The information here should not be relied on without clarification with Gentec. Gentec reserves the right to make design changes at any time without notification.

*Subject to terms and conditions. For detailed warranty information, installation compliance, maintenance and cleaning guidelines, and other relevant details, please visit <https://gentecaustralia.com.au>

gentecaustralia.com.au