

USER MANUAL

TEMPSET Lead Free Brass Thermostatic Mixing Taps

- **MVPMLF10100** - NSW Health Approved Lead Free DZR Brass Hob Mounted Point-of-Use Thermostatic Mixing Tap w/ 100mm Lever
- **MVPMLF10150** - NSW Health Approved Lead Free DZR Brass Hob Mounted Point-of-Use Thermostatic Mixing Tap w/ 150mm Lever
- **MVPMLF20100** - NSW Health Approved Lead Free DZR Brass In-Wall Point-of-Use Thermostatic Mixing Shower w/ 100mm Lever
- **MVPMLF30100** - NSW Health Approved Lead Free DZR Brass Wall Mounted Point-of-Use Thermostatic Mixing Tap w/ 100mm Lever
- **MVPMLF30150** - NSW Health Approved Lead Free DZR Brass Wall Mounted Point-of-Use Thermostatic Mixing Tap w/ 150mm Lever
- **MVPMLF20AV** - NSW Health Approved Lead Free DZR Brass Wall Mounted Point-of-Use Thermostatic Mixing Shower w/ Anti- Ligature Handle
- **MVPMLF5000** - NSW Health Approved Lead Free DZR Brass In-Wall Point-of-Use Thermostatic Mixing Valve w/ Temperature Control Dial, Electronic Tap Outlet and In-Wall Stainless Steel Enclosure
- **MVPMLF5250** - NSW Health Approved Lead Free DZR Brass In-Wall Point-of-Use Thermostatic Mixing Valve w/ 150mm Lever Handle and 250mm Fixed Spout, Complete with In-Wall Stainless Steel Enclosure



USER MANUAL

Table of Contents

Scope of Use	2
Technical Information	3
Product Images & Technical Drawings	4
Exploded Drawings	8
Installation Steps	14
Cleaning & Maintenance	18
Technology	31
Temperatures & Pressures	32
Troubleshooting	33
Water Quality	35
Responsibly Sourced	36
Commissioning Report	37
Service Report	39

Scope of Use

Installation of all products should adhere to the manufacturer's guidelines, as well as comply with PCA, AS/NZS3500, AS4032 standards, and any other relevant regulatory provisions.

This product range complies with the Lead Free requirements of the National Construction Code Volume Three.

- **Installation:** Refer to the installation instructions included within this manual
- **Water quality:** In line strainer (supplied) must be installed to ensure water quality
- **Suitable for indoor use**
- **Temperature recommendation:**
 - Working Temperature: 10°C - 50°C
- **Mounting:** Bench or wall mounted installation

Technical Information

Body Material	Lead Free DZR Brass
Cartridge	Thermostatic
Inlet	<ul style="list-style-type: none"> • MVPMLF10100 & MVPMLF10150: 15 mm Female Flexible Connections • MVPMLF30100 & MVPMLF30150: 15mm Female • MVPMLF20100, MVPMLF20AV & MVPMLF5250: 15mm
Flow Style	Thermostatic Mixing Taps & Thermostatic Mixer: Laminar Flow
Finish	<ul style="list-style-type: none"> • Thermostatic Mixing Taps & Thermostatic Mixing Showers: Chrome Plated • Thermostatic Mixer: (Lid: Polished Stainless Steel, Spout: Chrome Plated)
Servicing	Preventative Maintenance

USER MANUAL

Product Images & Technical Drawings

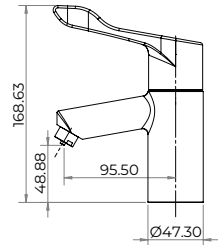
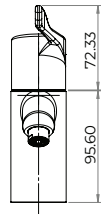
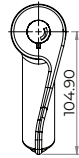

MVPMLF10100

NSW Health Approved Lead Free DZR Brass Hob Mounted Point-of-Use Thermostatic Mixing Tap w/ 100mm Lever

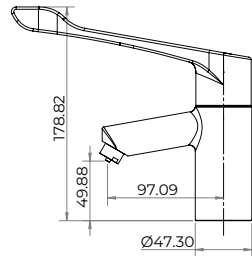
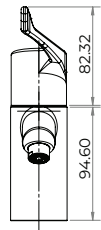
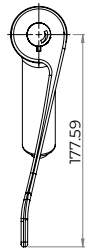

MVPMLF10150

NSW Health Approved Lead Free DZR Brass Hob Mounted Point-of-Use Thermostatic Mixing Tap w/ 150mm Lever

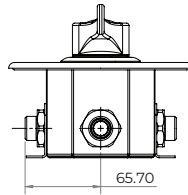
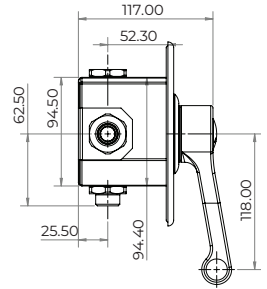
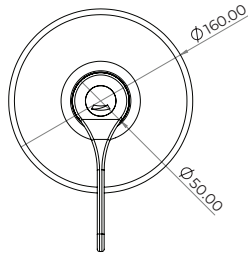

MVPMLF20100

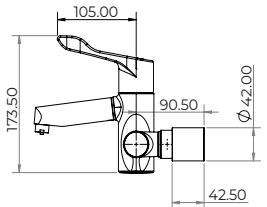
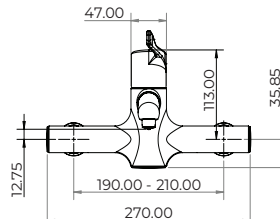
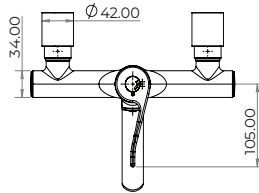
NSW Health Approved Lead Free DZR Brass In-Wall Point-of-Use Thermostatic Mixing Shower w/ 100mm Lever

MVPMLF30100

NSW Health Approved Lead Free DZR Brass Wall Mounted Point-of-Use Thermostatic Mixing Tap w/ 100mm Lever

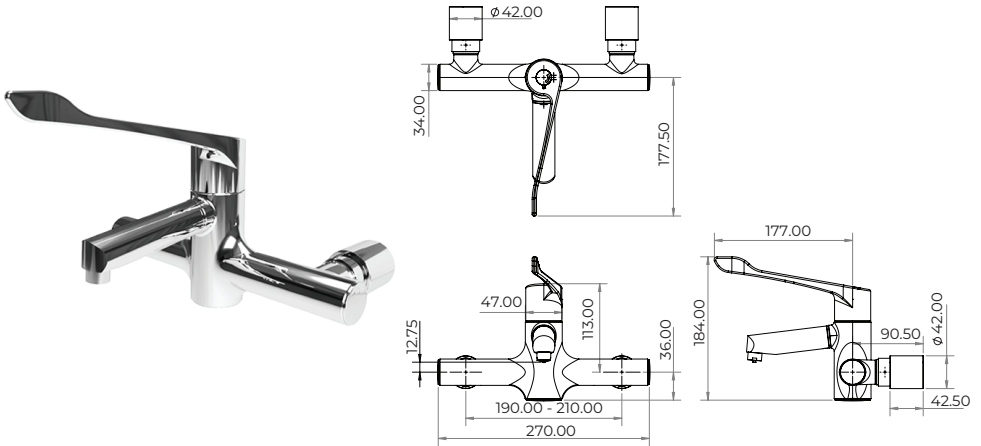
USER MANUAL



MVPMLF30150

NSW Health Approved Lead Free DZR Brass Wall Mounted Point-of-Use Thermostatic Mixing Tap w/ 150mm Lever

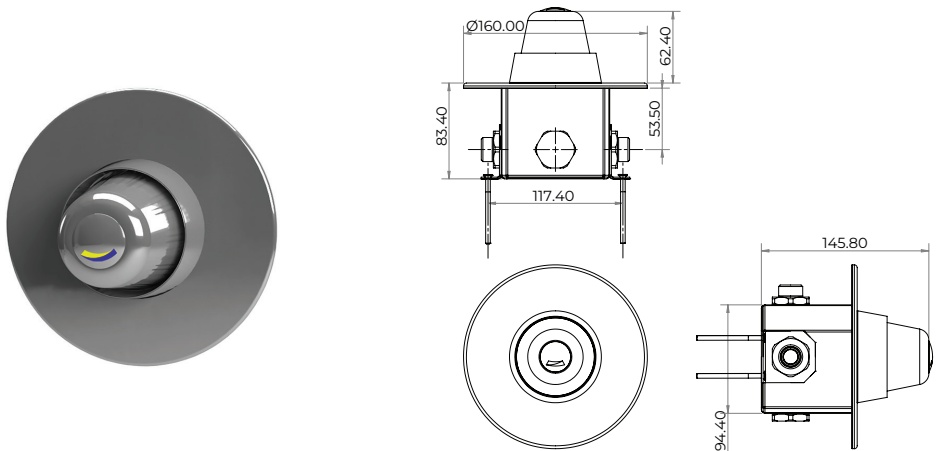

MVPMLF20AV

NSW Health Approved Lead Free DZR Brass Wall Mounted Point-of-Use Thermostatic Mixing Shower w/ Anti- Ligature Handle

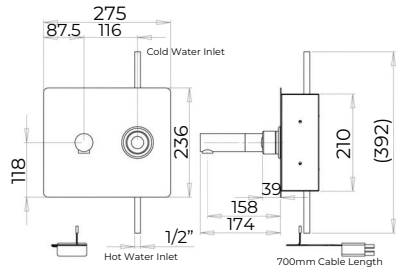
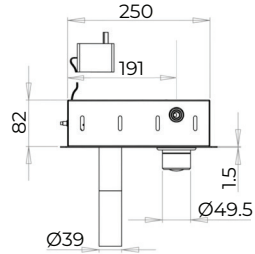

MVPMLF5000

NSW Health Approved Lead Free DZR Brass In-Wall Point-of-Use Thermostatic Mixing Valve w/ Temperature Control Dial, Electronic Tap Outlet and In-Wall Stainless Steel Enclosure

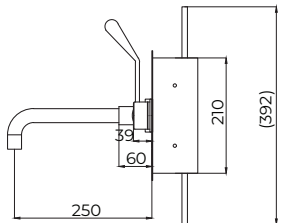
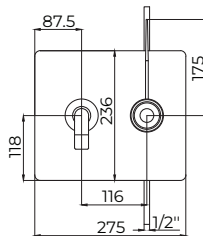
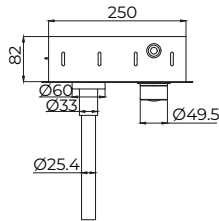

MVPMLF5250

NSW Health Approved Lead Free DZR Brass In-Wall Point-of-Use Thermostatic Mixing Valve w/ 150mm Lever Handle and 250mm Fixed Spout, Complete with In-Wall Stainless Steel Enclosure

Note: Dimensions are provided as a guide and are subject to manufacturing tolerances.

USER MANUAL

Exploded Drawings

MVPMLF10100

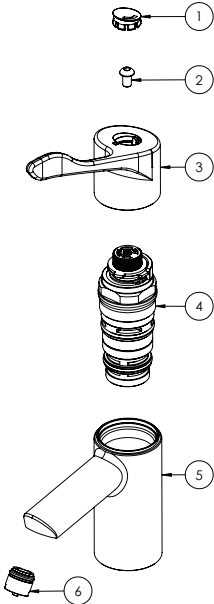

Item #	Description	Qty.	
1	Indicator & Screw Cover	1	
2	Screw	1	
3	Handle	1	
4	Thermostatic Cartridge	Preventative Maintenance	1
5	Mixer Body	1	
6	Aerator Housing & Aerator	Preventative Maintenance	1
7	Strainer (Hot & Cold)	2	
8	Non-return Valve (Hot & Cold)	2	

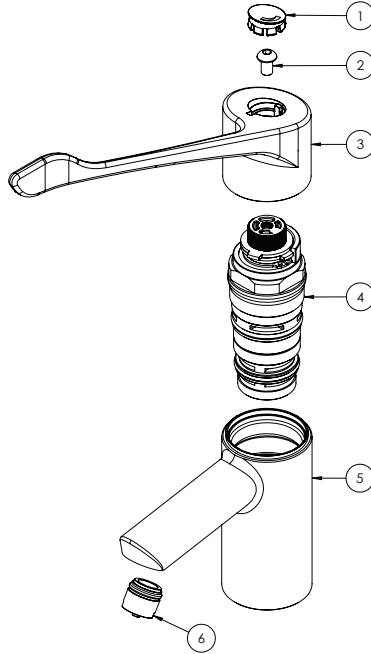
MVPMLF10150

Item #	Description	Qty.
1	Indicator & Screw Cover	1
2	Screw	1
3	Handle	1
4	Thermostatic Cartridge	1
5	Mixer Body	1
6	Aerator Housing & Aerator	1
7	Strainer (Hot & Cold)	2
8	Non-return Valve (Hot & Cold)	2
9	Hose	1

USER MANUAL

MVPMLF20100

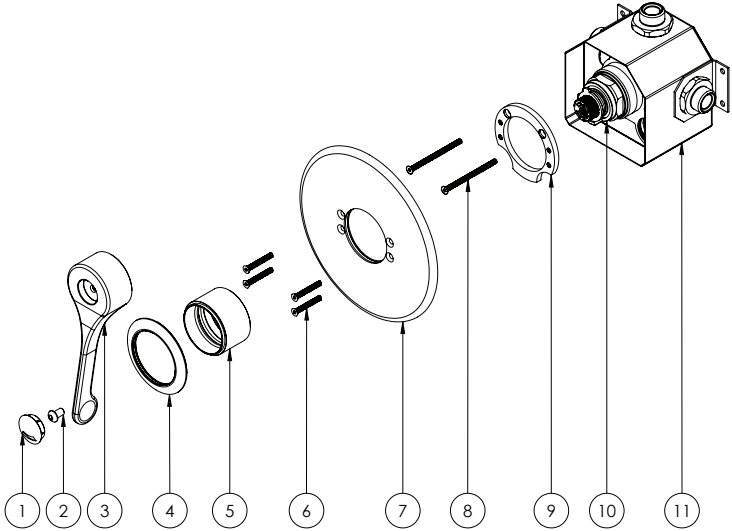

Item #	Description	Qty.
1	Indicator Cover	1
2	Handle Screw	1
3	Handle	1
4	Handle Flange	1
5	Handle Cover	1
6	M4 x 30mm Cover Plate Screws	4
7	Cover Plate (MVPM2042)	1
8	M4 x 60mm Fixing Screws	2
9	Fixing Plate	1
10	Thermostatic Cartridge	Preventative Maintenance
11	Box	1

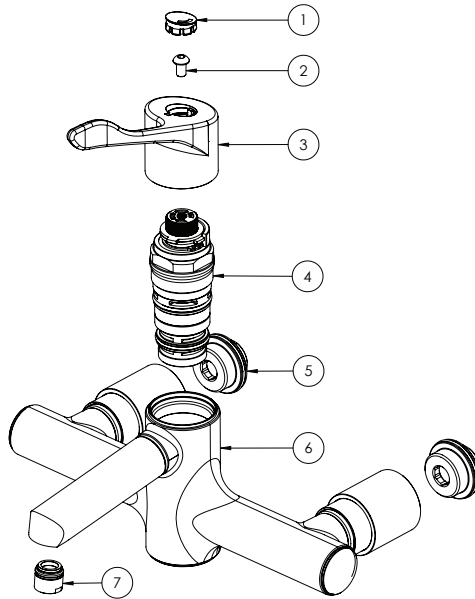
MVPMLF30100

Item #	Description	Qty.	
1	Indicator & Screw Cap	1	
2	Screw	1	
3	Handle	1	
4	Thermostatic Cartridge	Preventative Maintenance	1
5	Fixing Nut	2	
6	Mixer Body	1	
7	Aerator Housing & Aerator	Preventative Maintenance	1
8	Strainer (Hot & Cold)	2	
9	Non-return Valve (Hot & Cold)	2	

USER MANUAL

MVPMLF30150

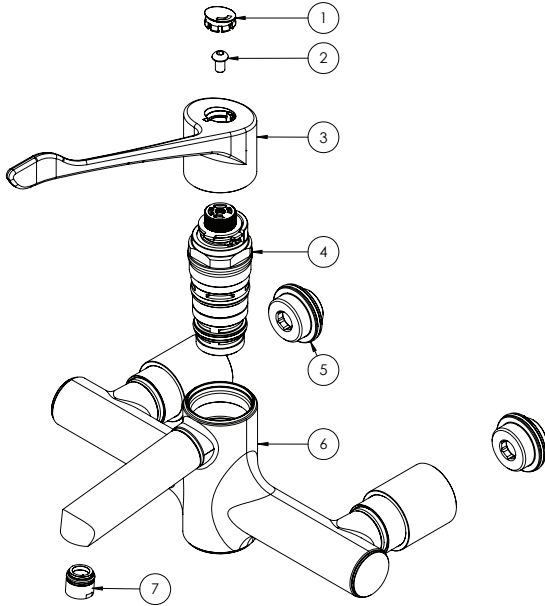

Item #	Description	Qty.	
1	Indicator & Screw Cap	1	
2	Screw	1	
3	Handle	1	
4	Thermostatic Cartridge	Preventative Maintenance	1
5	Fixing Nut	2	
6	Mixer Body	1	
7	Aerator Housing & Aerator	Preventative Maintenance	1
8	Strainer (Hot & Cold)	2	
9	Non-return Valve (Hot & Cold)	2	

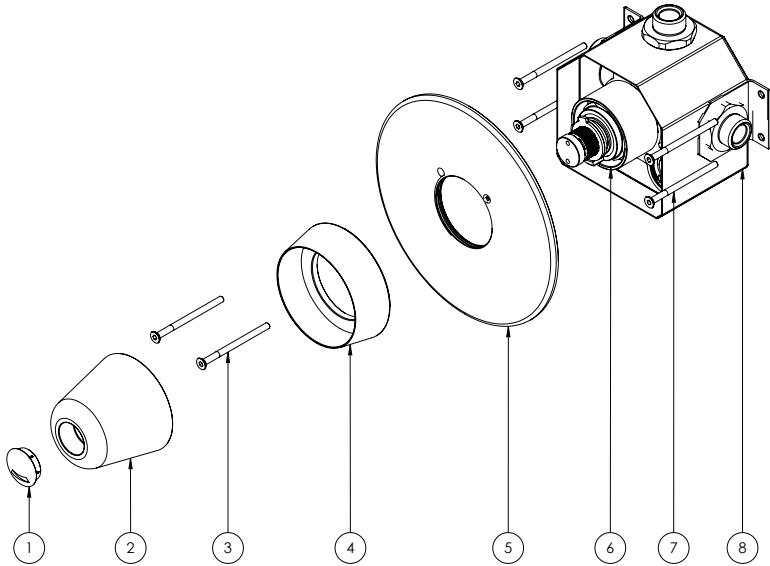
MVPMLF20AV

Item #	Description	Qty.
1	Indicator & Screw Cover	1
2	Handle	1
3	Flange Screws	2
4	Flange	1
5	Cover Plate	1
6	Thermostatic Cartridge	1
7	Wall Screws	4
8	Box	1
9	Strainer (Hot & Cold)	2
10	Non-return Valve (Hot & Cold)	2

USER MANUAL

Installation Steps

Important Information

The TEMPSET thermostatic mixing valve taps must be installed in accordance with the appropriate Standards, Code of Practice and legislation applicable to the point of install. The TEMPSET thermostatic mixing valve taps must be installed and serviced by an endorsed licensed plumber.

If the valve is not installed correctly then it will not function as designed and may put the user in danger. It shall also void the warranty of the product.

Prior to the installation of the TEMPSET mixing valve tap, the hot and cold system must be checked to ensure that the system operating conditions fall within the recommended operating range of the TEMPSET thermostatic mixing valve tap.

If the hot water supply temperature is greater than 90° Celsius, the valve may be damaged. If the temperature of the hot water will rise above 90° Celsius, a suitable temperature limiting valve must be fitted to the hot water supply, prior to the valve inlet fittings. This temperature limiting valve must be installed as per the manufacturer's installation requirements and Australian standards.

It is vital that both inlet dynamic supply pressure is **less than 500kPa** and of equal supply. **If either supply pressure exceeds 500kPa then a suitable pressure reducing valve must be fitted prior to the inlet control valve** of the TEMPSET thermostatic mixing valve to reduce the pressure to an acceptable limit.

To accomplish optimum performance from the TEMPSET thermostatic mixing valve tap is recommended that the inlet pressures are balanced to within 10% (6:1 ratio) of each other.

To ensure that the TEMPSET mixing valve tap operates correctly, it is necessary that **all associated pipework is thoroughly flushed with clean water before the valve is installed and operated.** This will remove any physical contaminants from the pipe work, ensuring trouble-free operation.

The valve should be installed in a convenient place to be **easily accessed for maintenance or servicing.** During installation or servicing, heat must not be applied near the mixing valve body or valve inlet fittings, as this will damage the mixing valve tap and inlet fittings internal workings. Failure to comply with this requirement will damage the valve and fittings. This will put the user at risk, and will void the warranty of the TEMPSET mixing valve tap.

MVPMLF10100 & MVPMLF10150 INSTALLATION INSTRUCTIONS

General Installation Requirements

Product must be installed in accordance with manufacturer's recommendations and to AS/NZS3500. Product must be installed by a licensed plumber and commissioned by a certified plumber.

General Installation and Commissioning Instructions

Flush all lines prior to installation to ensure all debris has been removed.

- Step 1. Isolate water supply before commencing installation.
- Step 2. Ensure sealing O-Ring is positioned on the base of the body.
- Step 3. Screw the mounting stud on to the base of the body.
- Step 4. Screw the inlet flexible hoses into the base of the body.
- Step 5. Slide the inlet flexible hoses through the hole in the basin/sink.
- Step 6. From the underside of the hob, slide on the rubber and metal washer then thread on the Hob fixing nut and tighten.
Note: Do not over tighten this hob fixing nut. In some cases this may cause cracking in some ceramic basins.
- Step 7. Connect each flexible hose to their respective water supply.

Please ensure the cold water inlet (indicated by a blue dot on the bottom of the body) is connected to the cold water supply. Please ensure the hot water inlet (indicated by a red dot on the bottom of the body) is connected to the hot water supply.

Note: AS/NZS:3500 stipulates that these flexible hoses must be connected directly to isolation valves installed in this position.

- Step 8. Perform temperature adjustment as per pages 25-26, if required. Place handle in position over spline and secure with supplied screw. Place temperature indicator cover and push in place.
- Step 9. Operate the handle from left to right (anti clockwise), and verify the water temperature increases as the handle is turned.
- Step 10. Complete the commissioning report on pages 38-39.

USER MANUAL

MVPMLF20100 & MVPMLF20AV INSTALLATION INSTRUCTIONS

General Installation Requirements

Product must be installed in accordance with manufacturer's recommendations and to AS/NZS3500. Product must be installed by a licensed plumber and commissioned by a certified plumber.

Commissioning and maintenance must comply with the local legislation and Australian standards code AS 4032.4.

General Installation and Commissioning Instructions

Flush all lines prior to installation to ensure all debris has been removed.

- Step 1. Secure the shower box to the internal cavity within the wall. The shower box can be fixed to a masonry wall or wall frame by using the fixing brackets on the inlet connections and four screws.
- Step 2. Connect the water supplies to the hot and cold inlets. The mixer body has red and blue markings to indicate the appropriate supply required for each side of the mixer.
- Step 3. Screw the chrome cover rose on to the body.
- Step 4. Seal the faceplate to the wall using a suitable sealant.
- Step 5. Place the handle over the spline and to test that the handle is moving freely, then remove.

For MVPMLF20AV

- Step 6. Secure the flange using the M4 post screws. This will compress the faceplate to the wall. Remove any excess sealant that may be present after this step.
- Step 7. Place the handle over the spline, then secure with supplied screw. Push in indicator cover.

For MVPMLF20100

- Step 8. Fit the dress ring over the cover rose on the body, then push on to the faceplate.
- Step 9. Place the handle over the spline, then secure with supplied screw. Push in indicator cover.

MVPMLF30100 & MVPMLF30150 INSTALLATION INSTRUCTIONS
General Installation Requirements

Product must be installed in accordance with manufacturer's recommendations and to AS/NZS 3500. Product must be installed by a licensed plumber and commissioned by a certified plumber.

Commissioning and maintenance must comply with the local legislation and Australian standards code AS/NZS 4032.1.

General Installation and Commissioning Instructions

Flush all lines prior to installation to ensure all debris has been removed.

- | | |
|-------------------------------------------------------------------------------------------------------------------------------------------------------------------------------------------|---------------------------------------------------------------------------------------------------------------------------------------------|
| <p>Step 1. Ensure set out dimensions are appropriate and that the fit out has 2 x G1/2 male nipples protruding from the wall. Ensure these threads are no longer than 15mm in length.</p> | <p>Step 8. Tighten the nuts on the tap body inlets to the wall adapters (already fastened to the wall).</p> |
| <p>Step 2. Apply an approved thread sealant to the exposed male nipples.</p> | <p>Step 9. Slide the chrome covers over the nuts on the tap body inlets.</p> |
| <p>Step 3. Remove chrome covers from the wall adapters.</p> | <p>Step 10. Perform servicing and temperature adjustment as per page 25-26.</p> |
| <p>Step 4. Thread on wall adapters to the male nipples. Tighten accordingly.</p> | <p>Step 11. Place handle in position over spline and secure with supplied screw. Place temperature indicator cover and push in place.</p> |
| <p>Step 5. Replace chrome covers on the wall adapters.</p> | <p>Step 12. Operate the handle from left to right (anti clockwise), and verify the water temperature increases as the handle is turned.</p> |
| <p>Step 6. Pull back the chrome covers on the inlets of the tap body.</p> | <p>Step 13. Complete the commissioning report as per pages 38-39.</p> |
| <p>Step 7. Fit strainers and fiber washers to the tap body inlets.</p> | |

USER MANUAL

Cleaning & Maintenance

To minimise downtime and maximise the functional life of the product, GENTEC recommends servicing your product at least every 12 months, under heavy use may need to be checked and serviced more often.

- The product must be handled carefully to avoid causing any physical damage.
- Use the product at least once every week to ensure all parts are kept lubricated and functioning properly.
- Service the product at least once a year to avoid any product failures - The service timeline provided is based on normal use. More frequent servicing may be required for heavy usage.
- A working pressure of 350kPa is highly recommended to ensure the maximum up-time of the product.
- Regularly clean the product with a soft cloth with warm soapy water, wash off with warm water and dry off with a soft dry cloth, paying attention to removing the dust and contamination in the bends and joints is highly recommended.
- Abrasives, hard clothes, strong acids, and bleaches must be avoided when cleaning all GENTEC products.

The TEMPSET Thermostatic Mixing Tap will only require minimal preventative maintenance work to ensure it operates at its designed level of performance.

The valve should be commissioned and serviced annually, unless the installed conditions dictate more frequent servicing is required or requested. All servicing and commissioning should be undertaken by an endorsed qualified plumber.

ANNUAL MAINTENANCE REQUIREMENTS: FOR MVPMLF10100 & MVPMLF10150

The TEMPSET thermostatic mixer tap should be inspected and tested in accordance with Gentec Requirements, AS 4032.4 and AS3500 and any local authority requirements.

Every 12 months GENTEC recommends that the thermostatic mixer taps should be :

1. Visually inspected for leaks or damage,
2. Outlet temperature checked with set temperature.
3. Remove, clean and check strainers and non return valves. Please follow these steps.
 - a) Isolate both water supplies.
 - b) Ensure that both water supplies have been isolated by opening the mixer (no water should flow).
 - c) Unscrew non return valve / strainer fitting from flexible hoses and water inlets.
 - d) Remove clips from both fittings using a circlip pliers.
 - e) Remove strainer and non return valve.
 - f) Strainers should be cleaned with a descaling agent and rinsed with water.
 - g) Clean and replace any broken components.
 - h) Restore initial conditions.
4. Thermal shutdown should be completed and temperature retaken after thermal shutdown (if valve fails to shut down or fails to maintain temperature then refer to trouble shooting).

Note: Ensure correct documentation is completed annually in accordance with AS4031.1 requirements.

ANNUAL MAINTENANCE REQUIREMENTS: FOR ALL TEMPSET MIXING SHOWERS

The TEMPSET thermostatic mixer tap should be inspected and tested in accordance with Gentec Requirements, AS 4032.4 and AS3500 and any local authority requirements.

Every 12 months GENTEC recommends that the thermostatic mixer taps should be :

1. Visually inspected for leaks or damage,
2. Outlet temperature checked with set temperature.
3. Remove, clean and check strainers and non return valves:
 - a) Isolate both water supplies.
 - b) Ensure that both water supplies have been isolated by opening the mixer (no water should flow).
 - c) Remove the indicator cover and handle.
 - d) Remove Flange and then cover plate.
 - e) Remove clips from the both isolation valves using a circlip pliers.
 - f) Remove strainer and non-return valve using an Allen Key.
 - g) Strainers should be cleared with a descaling agent and rinsed with water.
 - h) Clean and replace any broken components.
 - i) Restore initial conditions.
4. Thermal shutdown should be completed and temperature retaken after thermal shutdown (if valve fails to shut down or fails to maintain temperature then refer to trouble shooting)

Note: Ensure correct documentation is completed annually in accordance with AS 4032.4 requirements.

ANNUAL MAINTENANCE REQUIREMENTS: FOR MVPMLF30100 & MVPMLF30150

The TEMPSET thermostatic mixer tap should be inspected and tested in accordance with Gentec Requirements, AS 4032.4 and AS3500 and any local authority requirements.

Every 12 months GENTEC recommends that the thermostatic mixer taps should be :

1. Visually inspected for leaks or damage,
2. Outlet temperature checked with set temperature.
3. Remove, clean and check strainers and non return valves.
 - a) Isolate both water supplies.
 - b) Ensure that both water supplies have been isolated by opening the mixer (no water should flow).
 - c) Pull back the chrome covers on the inlets of the tap body.
 - d) Loosen the nuts on the tap body inlets to the wall adapters.
 - e) Remove and inspect strainer.
 - f) Remove clips using circlip pliers and inspect the non-return valve.
 - g) Strainers should be cleaned with a descaling agent and rinsed with water.
 - h) Clean and replace any broken components.
 - i) Restore initial conditions.
4. Thermal shutdown should be completed and temperature retaken after thermal shutdown (if valve fails to shut down or fails to maintain temperature then refer to troubleshooting)

Note: Ensure correct documentation is completed annually in accordance with AS 4032.4 requirements.

USER MANUAL

FIVE-YEAR MAINTENANCE REQUIREMENTS: FOR MVPMLF10100 & MVPMLF10150

Every five years the TEMPSET thermostatic mixer tap needs to have the mixer cartridge replaced along with a full service carried out.

1. Removal and inspection of cartridge procedure - MVPMLF10100, MVPMLF10150

Step 1. Isolate the fitting by turning the isolating valves 90° anti-clockwise (viewed facing the isolation valve).

Step 2. Remove the lever handle (3). Unscrew the cartridge (4) from the body (5) with a 36mm AF deep socket. Clean all components thoroughly and inspect cartridge for damage. If the components are damaged, the cartridge must be replaced.

Step 3. The cleaned cartridge (4) (or a new cartridge, if this is required) can now be re-installed, by screwing into the mixer body (5) until it reaches a firm stop and tightened.

Step 4. The cartridge should be tightened to a torque of 15Nm.

Step 5. Replace lever handle (3) and reinstate the water supplies.

Step 6. After fitting the new cartridge, perform the commissioning procedure.

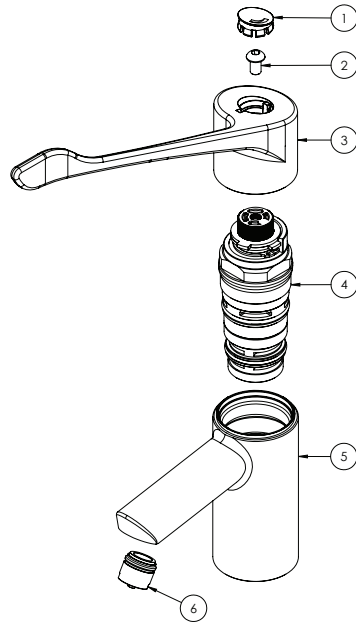

When service is complete, slowly open the cold water isolation valve and inspect mixer body for leaks. Repeat with hot water isolation valves.

Open the mixer by rotating handle anti-clockwise and check operation and flow.

2. Commission and Annual Service Procedure, please refer to pages 15-19.

3. Thermal Shut Down Test Procedure:

After replacing the thermostatic mixer cartridge, a thermal shut down test must be completed, and the temperature re-set as required. If the valve fails to shut down or fails to maintain its set temperature, then refer to the troubleshooting section.

Once the correct outlet temperature has been achieved, the valve's internal mechanism should be exercised at least 3 times by alternately shutting off the hot and cold supplies while the mixer is set in the full warm position, do this at the outlet using the mixer's separate Hot and Cold isolation Valves. This will cause the piston inside the cartridge to travel its full stroke and ensure that it is moving freely so the valve can operate correctly.

Test 1 Cold water isolation (accordance with AS 4032.4, Appendix F)

- Step 1. Open mixer to the full warm position and with hot and cold water supplies turned fully on and the system's temperatures, allow the mixed water temperature to stabilise and note the outlet temperature.
- Step 2. While holding a digital thermometer at the thermostatic mixer taps outlet water flow, quickly isolate the cold water supply to the mixing valve. The outlet flow should quickly near cease flowing. As an industry rule of thumb, the flow should be less than 0.1L/min following the isolation. The temperature should not exceed that allowed by the applicable Australian standard AS 4032.4 and desired local authority requirements e.g.: Hosplan and code of practice for each state.
- Step 3. Restore the cold water supply to the mixing valve. After the mixed water temperature has stabilised note the outlet temperature ensuring the outlet temperature has re-established.

Test 2 Hot water isolation (accordance with AS 4032.4, Appendix F)

- Step 1. Repeat the above test, except this time quickly isolate the hot water supply to the thermostatic mixing tap. The outlet flow should quickly slow to a trickle. As an industry rule of thumb the trickle should typically be less than 0.4L/min@500kPa down to less than 0.1L/min@100kPa following the isolation.
- Step 2. Restore the hot water supply to the valve and measure and record the outlet temperature after the mixed water temperature has stabilised ensuring the outlet temperature has re-established.

Ensure that all details of the Commissioning Report are completed and signed by the relevant signatories, and a copy is kept with the installer and owner of the premises. The valve is now commissioned, and it can be used within the technical limits of operation.

Once the 5 yearly maintenance procedure is complete, the thermostatic mixer should then be commissioned as per AS 4032.4 requirement.

USER MANUAL

FIVE-YEAR MAINTENANCE REQUIREMENTS: FOR ALL TEMPSET MIXING SHOWERS

Every five years the TEMPSET thermostatic mixer tap needs to have the mixer cartridge replaced along with a full service carried out.

1. Removal and inspection of cartridge procedure - MVPMLF20100, MVPMLF20AV

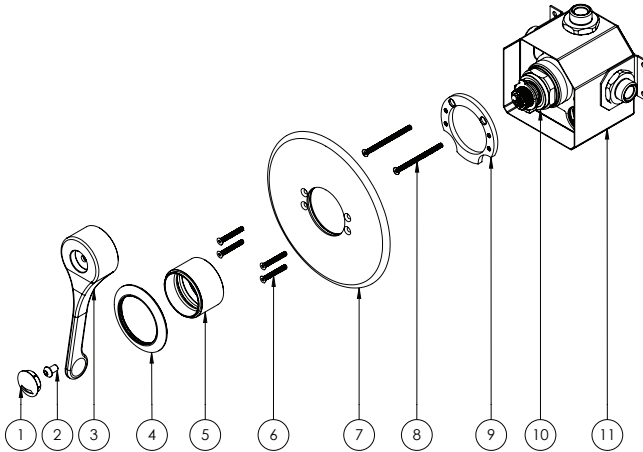

Step 1. Isolate the fitting by turning the isolating valves 90° anti-clockwise (viewed facing the isolation valve).

Step 2. Remove the lever handle. Unscrew the cartridge from the body with a 36mm AF deep socket. Clean all components thoroughly and inspect cartridge for damage. If the components are damaged, the cartridge must be replaced.

Step 3. The cleaned cartridge (or a new cartridge, if this is required) can now be re-installed, by screwing into the mixer body until it reaches a firm stop and tightened.

Step 4. The cartridge should be tightened to a torque of 15Nm.

Step 5. Replace lever handle and reinstate the water supplies.

Step 6. After fitting the new cartridge, perform the commissioning procedure.

When service is complete, slowly open the cold water isolation valve and inspect mixer body for leaks. Repeat with hot water isolation valves.

Open the mixer by rotating handle anti-clockwise and check operation and flow.

2. Commission and Annual Service Procedure, please refer to pages 15-19.

3. Thermal Shut Down Test Procedure:

After replacing the thermostatic mixer cartridge, a thermal shut down test must be completed, and the temperature re-set as required. If the valve fails to shut down or fails to maintain its set temperature, then refer to the troubleshooting section.

Once the correct outlet temperature has been achieved, the valve's internal mechanism should be exercised at least 3 times by alternately shutting off the hot and cold supplies while the mixer is set in the full warm position, do this at the outlet using the mixer's separate Hot and Cold isolation Valves. This will cause the piston inside the cartridge to travel its full stroke and ensure that it is moving freely so the valve can operate correctly.

Test 1 Cold water isolation (accordance with AS 4032.4, Appendix F)

- Step 1. Open mixer to the full warm position and with hot and cold water supplies turned fully on and the system's temperatures, allow the mixed water temperature to stabilise and note the outlet temperature.
- Step 2. While holding a digital thermometer at the thermostatic mixer taps outlet water flow, quickly isolate the cold water supply to the mixing valve. The outlet flow should quickly near cease flowing. As an industry rule of thumb, the flow should be less than 0.1L/min following the isolation. The temperature should not exceed that allowed by the applicable Australian standard AS 4032.4 and desired local authority requirements e.g.: Hosplan and code of practice for each state.
- Step 3. Restore the cold water supply to the mixing valve. After the mixed water temperature has stabilised note the outlet temperature ensuring the outlet temperature has re-established.

Test 2 Hot water isolation (accordance with AS 4032.4, Appendix F)

- Step 1. Repeat the above test, except this time quickly isolate the hot water supply to the thermostatic mixing tap. The outlet flow should quickly slow to a trickle. As an industry rule of thumb the trickle should typically be less than 0.4L/min@500kPa down to less than 0.1L/min@100kPa following the isolation.
- Step 2. Restore the hot water supply to the valve and measure and record the outlet temperature after the mixed water temperature has stabilised ensuring the outlet temperature has re-established.

Ensure that all details of the Commissioning Report are completed and signed by the relevant signatories, and a copy is kept with the installer and owner of the premises. The valve is now commissioned, and it can be used within the technical limits of operation.

Once the 5 yearly maintenance procedure is complete, the thermostatic mixer should then be commissioned as per AS 4032.4 requirement.

USER MANUAL

FIVE-YEAR MAINTENANCE REQUIREMENTS: FOR MVPMLF30100 & MVPMLF30150

Every five years the TEMPSET thermostatic mixer tap needs to have the mixer cartridge replaced along with a full service carried out.

1. Removal and inspection of cartridge procedure - MVPMLF30100, MVPMLF30150

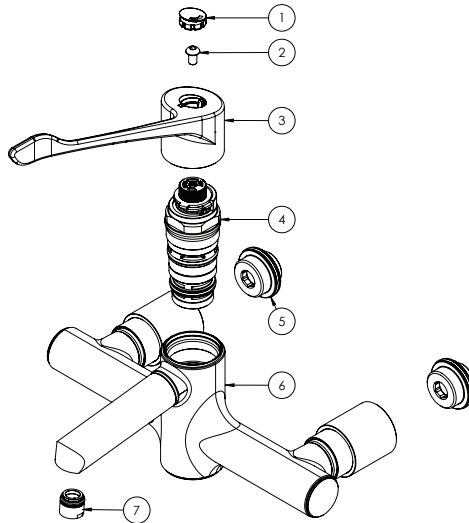

Step 1. Isolate the fitting by turning the isolating valves 90° anti-clockwise (viewed facing the isolation valve).

Step 2. Remove the lever handle. Unscrew the cartridge from the body with a 36mm AF deep socket. Clean all components thoroughly and inspect cartridge for damage. If the components are damaged, the cartridge must be replaced.

Step 3. The cleaned cartridge (or a new cartridge, if this is required) can now be re-installed, by screwing into the mixer body until it reaches a firm stop and tightened.

Step 4. The cartridge should be tightened to a torque of 15Nm.

Step 5. Replace lever handle and reinstate the water supplies.

Step 6. After fitting the new cartridge, perform the commissioning procedure.

When service is complete, slowly open the cold water isolation valve and inspect mixer body for leaks. Repeat with hot water isolation valves.

Open the mixer by rotating handle anti-clockwise and check operation and flow.

MIXING CARTRIDGE TEMPERATURE ADJUSTMENT (TYPICAL TO ALL MIXERS)

Step 1. Remove the top cap, screw and handle. Ensure that the mixer cartridge is closed.

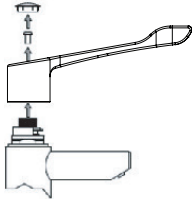

Step 2. Remove the upper brass ring (closure setting ring) Make sure the control rod doesn't rotate.



Step 3. Remove the lower brass ring and rotate the brass ring clockwise to increase temperature or anti-clockwise to decrease.



Step 4. Reposition the upper ring in the same position.



Step 5. Test the set temperature. If the temperature is acceptable, reposition the handle, the screw and the top cap otherwise repeat steps 3 to 5.

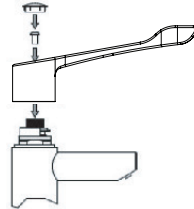

USER MANUAL

Step 1.

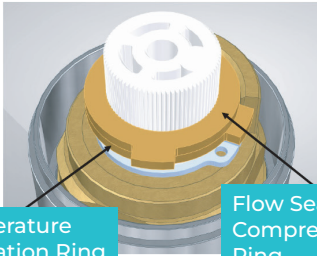

Temperature
Calibration Ring

Flow Seal
Compression
Ring

Step 2. Remove the flow closure ring and rotate it counterclockwise to increase the closure.

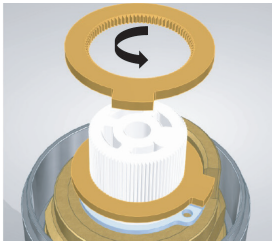

Step 3. Replace the ring in its seat.

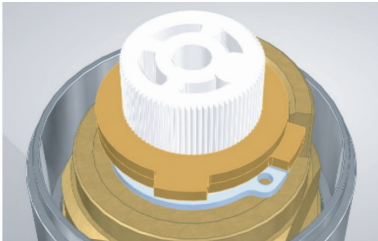

Step 4. If you want to re-calibrate the temperature, remove the flow closure ring.

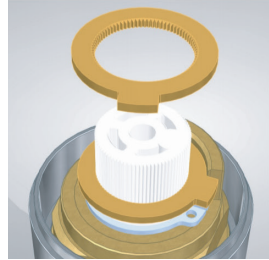

Step 5. Remove the temperature calibration ring and rotate it counterclockwise to decrease the temperature. Rotate it clockwise if you want to increase the temperature.

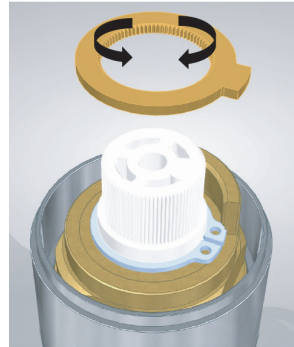

Step 6. Replace the rings.

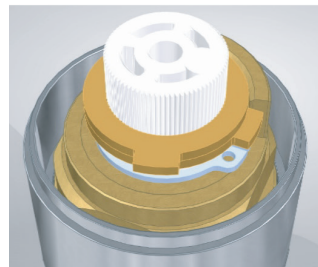

DISINFECTION PROCEDURE

Safety Notes for all units: Care should be taken when carrying out the following procedure to avoid contact with hot water and hot surfaces. We recommend the use of protective hand wear.

This procedure is recommended every 12 months to reduce the risk of legionella and bacteria for high level care areas.

Table 1:

Disinfection Temperature	Time (Minutes)
60°C	30 min.
65°C	15 min.
70°C	10 min.

Method 1 for MVPMLF10100, MVPMLF10150

To disinfect the fitting proceed as follows:

To complete the disinfection procedure on the units TEMPSET Bench Mounted Mixer Point-of-Use MVPMLF10100 and MVPMLF10150, it is recommended to purchase a blank cartridge.

This will allow you to push the system at higher temperature to eliminate bacteria growth.

- | | |
|---------------------------------------------------------------------------------------------------------------------------------------------------------------------------------------------------------------------------------------------------------------------------------------------------------------------------------------------------------------------------------------------------------------------------------------------------------------------------------------------------------------------------------------------------------------------------------------------------------------------------------------------------------------|--------------------------------------------------------------------------------------------------------------------------------------------------------------------------------------------------------------------------------------------------------------------------------------------------------------------------------------------------------------------------------|
| <p>Step 1. Before starting Isolate the hot and cold water at the isolation point.</p> <p>Step 2. Remove the temperature indicator and remove the screw with a 4mm Allen key to remove the Handle and gain access to the cartridge.</p> <p>Step 3. Remove the existing cartridge and replace with the Blank Cartridge available upon request.</p> <p>Step 4. Turn the hot water isolation back on and fit the lever handle to run the Hot water through the mixer.</p> <p>Step 5. See table 1 for a guide to disinfection temperatures v/s time.</p> <p>Step 6. Once the desired disinfection time is complete, isolate the hot water at the inlet.</p> | <p>Step 7. Remove the blank cartridge, replace it with the existing cartridge.</p> <p>Step 8. Turn on the Hot & Cold Isolation points to open water supply.</p> <p>Step 9. Test temperature at outlet and adjust if necessary. Refer to page 25-26.</p> <p>Step 10. Replace the lever handle in position, tighten the screw and push the colour temperature indicator.</p> |
|---------------------------------------------------------------------------------------------------------------------------------------------------------------------------------------------------------------------------------------------------------------------------------------------------------------------------------------------------------------------------------------------------------------------------------------------------------------------------------------------------------------------------------------------------------------------------------------------------------------------------------------------------------------|--------------------------------------------------------------------------------------------------------------------------------------------------------------------------------------------------------------------------------------------------------------------------------------------------------------------------------------------------------------------------------|

Please Note:

The tool used for this Thermal Disinfection Procedure is available as a Separate item.

Sales Code: **MVPM9000** - Blank Cartridge

USER MANUAL

Method 2 for MVPMLF10100

Step 1. Turn both handles of the isolation valves to the off position.

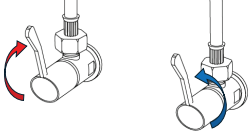

Step 2. Disconnect both hoses and switch them. The hot hose should now be connected to the cold outlet and the cold hose should now be connected to the hot outlet.

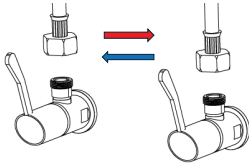

Step 3. Reconnect the hoses and turn on the **HOT OUTLET ONLY**.

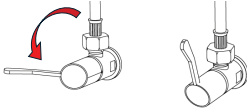

Step 4. Turn the tap to the open position.

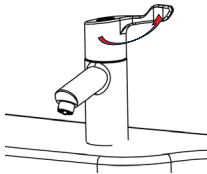

Step 5. Based on the temperature of the hot water outlet, leave the tap on for the following period. Ensure that all individuals keep clear of the tap to avoid burns.

Temperature	Disinfection
60°C	30 min.
65°C	15 min.
70°C	10 min.

Step 6. Turn the tap to the closed position. It is recommended to wait until the unit has cooled down before proceeding to avoid the risk of burns.

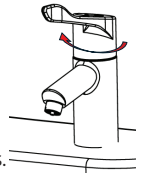

Step 7. Turn off the hot outlet.

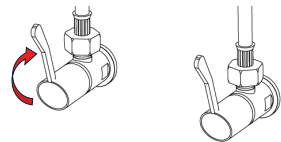

Step 8. Disconnect both hoses and return them to their original position.

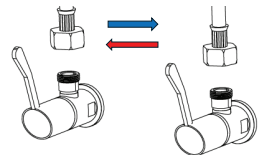

Step 9. Reconnect the hoses and turn on the isolation valves. Turn the tap on to ensure regular function has returned.

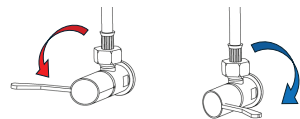

MVPMLF20100, MVPMLF20AV

To disinfect the fitting proceed as follows:

To complete the disinfection procedure on the units TEMPSET Shower Mixer Point-of-Use MVPMLF20100 and MVPMLF20AV, it is recommended to purchase a blank cartridge.

This will allow you to flush the system at higher temperature to eliminate bacteria growth.

- | | |
|--------------------------------------------------------------------------------------------------------------------------------------------------------------------------------------------------------------------------------------------------------------------------------------------------------------------------------------------------------------------------------------------------------------------------------------------------------------------------------------------------------------------------------------------------------------------------------------------------------------------------------------------------------------------------------------------------------------------------------------------------------------------------------------------------------------------------------------------------------------------------------------------------------------------------------------------------------------------------------------------------------|--------------------------------------------------------------------------------------------------------------------------------------------------------------------------------------------------------------------------------------------------------------------------------------------------------------------------------------------------------------------------------------------------------------------------------------------------------------------------------------------------------------------------------------------------------------------------------------------------------------------------------------|
| <p>Step 1. Remove the temperature indicator and remove the screw with a 4mm Allen key to remove the Handle and gain access to the Cartridge.</p> <p>Step 2. Remove the dressing ring by sliding forward, then remove the screws with a 2.5mm Allen key.</p> <p>Step 3. Remove the squared cover plate.</p> <p>Step 4. Isolate the hot and cold water at the isolation points by removing the circlips. Insert an 8mm Allen key, then turn anti-clockwise to shut water off on the hot and cold-water supply. Remove isolation fitting completely to clean strainer and double check valve.</p> <p>Step 5. Remove the existing cartridge with an adjustable spanner.</p> <p>Step 6. Replace the existing cartridge with the Blank Cartridge available upon request.</p> <p>Step 7. Replace the Hot water isolation fitting. Fit the lever handle to run the hot water through the mixer by using the handle to turn on water. See table 1 for a guide to disinfection temperatures v/s time.</p> | <p>Step 8. Once the desired disinfection time is complete, turn lever handle to off position.</p> <p>Step 9. Turn hot isolation fitting anti-clockwise to isolate..</p> <p>Step 10. Remove blank cartridge and replace existing blank cartridge.</p> <p>Step 11. Turn hot and cold isolation fittings clockwise to open water supply.</p> <p>Step 12. Test temperature at outlet and adjust if necessary. Refer to page 25-26.</p> <p>Step 13. Replace square cover plate.</p> <p>Step 14. Replace fixing screws.</p> <p>Step 15. Replace dressing ring and lever handle tighten screw and push in colour temperature indicator.</p> |
|--------------------------------------------------------------------------------------------------------------------------------------------------------------------------------------------------------------------------------------------------------------------------------------------------------------------------------------------------------------------------------------------------------------------------------------------------------------------------------------------------------------------------------------------------------------------------------------------------------------------------------------------------------------------------------------------------------------------------------------------------------------------------------------------------------------------------------------------------------------------------------------------------------------------------------------------------------------------------------------------------------|--------------------------------------------------------------------------------------------------------------------------------------------------------------------------------------------------------------------------------------------------------------------------------------------------------------------------------------------------------------------------------------------------------------------------------------------------------------------------------------------------------------------------------------------------------------------------------------------------------------------------------------|

USER MANUAL

MVPMLF30100 & MVPMLF30150 THERMAL DISINFECTION PROCEDURE

MVPMLF30100 and MVPMLF30150 have a by-pass device installed for Legionella disinfection. To use it:

Step 1. Slide the flange of the right wall inlet to reveal the screw. Using a screwdriver, rotate the screw clockwise to isolate the cold water.

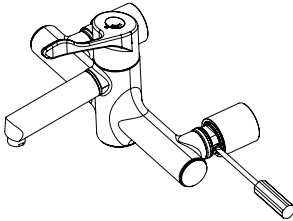

Step 2. Remove the cap from the base of the tap, beneath the handle. Insert the key into the hole at the base.

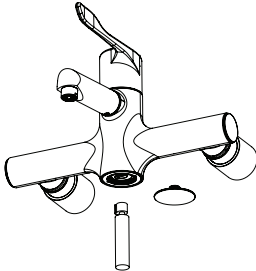

Step 3. Turn the key anti-clockwise as far as it can and then move the tap lever handle to the open position.

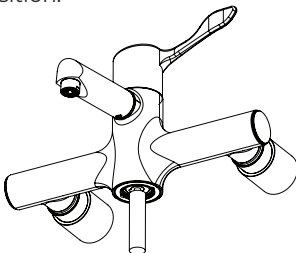

Step 4. To return the to normal operation mode, rotate the handle back to the closed position. Turn the key clockwise as far as it can, replace the cap on the bottom of the tap and reopen access to the hot water by rotating the isolation screw anti-clockwise.

Please Note:

The tool used for this Thermal Disinfection Procedure is available as a Separate item.

Sales Code: **MVPMLF9020** - Thermal Disinfection By-pass Key.

Technology

The TEMPSET single handed lever mixing will shut down in the event of cold or hot water failure and have been designed to provide water at an even, preset and safe temperature to prevent scalding. TEMPSET products deliver reliable performance and should be used wherever safe warm water is required.

The valve can be supplied in a wide range of configurations to satisfy any commercial installation examples Basin, Wall and Shower, Bath and Anti-ligature options. This unique technology is supplied as chrome plated bare valve, with a built in strainer, non-return valve and isolating valves.

PROGRESSIVE TEMPSET CODE NUMBER REFERENCE

Product Code	100mm Levers
MVPMLF10100	Lead Free DZR Brass Hob Mounted Point-of-Use Thermostatic Mixing Tap w/ 100mm Lever
MVPMLF20100	Lead Free DZR Brass In-Wall Point-of-Use Thermostatic Mixing Shower w/ 100mm Lever
MVPMLF30100	Lead Free DZR Brass Wall Mounted Point-of-Use Thermostatic Mixing Tap w/ 100mm Lever
Product Code	150mm Levers
MVPMLF10150	Lead Free DZR Brass Hob Mounted Point-of-Use Thermostatic Mixing Tap w/ 150mm Lever
MVPMLF30150	Lead Free DZR Brass Wall Mounted Point-of-Use Thermostatic Mixing Tap w/ 150mm Lever
Product Code	Anti-Ligature
MVPMLF10150	Lead Free DZR Brass Hob Mounted Point-of-Use Thermostatic Mixing Tap w/ 150mm Lever
MVPMLF20AV	Lead Free DZR Brass Wall Mounted Point-of-Use Thermostatic Mixing Shower w/ Anti-Ligature Handle

USER MANUAL

Temperatures & Pressures

Mixed Temperature	Min. temperature: 30°C Max. temperature: 48°C			
Factory Set Temperature	41°C			
Supply Temperature Range	5 Min. - 85 Max. (°C)			
Thermal Shut Off	Min. inlet temperature between hot and mixed 10°C Max inlet temperature between cold and mixed 10°C			
Minimum Temperature Differential (Between Supply & Outlet)	10°C			
Inlet Pressure Ratio	6:1			
Accuracy	±2°C			
Water Pressure	Static, Max 1000kPa			
Working Pressure	Dynamic, Max 500kPa			
Requirement (L/min)	Nominal Flow Rate	Highest Flow Rate	Lowest Flow Rate	Minimum Difference
	5.85	6.05	5.61	0.44

Important Information

For optimum performance, it is recommended to have the pressures and temperatures balanced.

It is essential to ensure your systems are compliant with AS3500 and AS4032.

Troubleshooting

Problem	Cause	How to Fix
Thermostatic valve is not working well	<ul style="list-style-type: none"> Valve is pulsating Humming Not enough flow 	<ul style="list-style-type: none"> Have you flushed the water line as per the instruction, this is VERY IMPORTANT AND CRITICAL during installation to do this correctly Please check the strainers for blockages, as well as the non-return valves and isolating valves If debris has gone through the cartridge this is more than likely to be the cause. If the cold water and hot water seats have been damaged, they must be replaced Have you checked to make sure the pressure is to manufacturer's recommendations and in line with the plumbing code Ensure you have adequate pressure on both hot and cold Temperature difference must be within tolerances Minimum flow and too many outlets can make the valve to pulsate
How many taps or showers can I install per valve	<ul style="list-style-type: none"> Not enough flow 	<ul style="list-style-type: none"> Ensure to size the valve correctly, what is the valve output, and then make sure the outlets you are using do not exceed what the valve is able to achieve. For example, if the pressure is 400 on both hot and cold, and your valve output is 42 lpm, this means you must not use any more than 42 lpm for all the outlets you are proposing to use
How often do I need to service the valve	<ul style="list-style-type: none"> Preventing issues 	<ul style="list-style-type: none"> The valve must be serviced annually and the O-Ring must be replaced using the manufacturer's parts only. However, in the event the valve is having any issues in between the 1 year period, then we recommend a full parts replacement
What parts do I need to replace and when	<ul style="list-style-type: none"> Preventing issues 	<ul style="list-style-type: none"> The wax element must be replaced every 5 years. However, in the event the valve is having any issues in between the 1 year period, then we recommend a full parts replacement

USER MANUAL

Problem	Cause	How to Fix
Thermostatic tap is not working well	<ul style="list-style-type: none"> Flow issues Humming Not enough flow 	<ul style="list-style-type: none"> Have you flushed the water line as per the instruction, this is VERY IMPORTANT AND CRITICAL during installation to do this correctly Please check the strainers for blockages, as well as the non-return valves and isolating valves If debris has gone through the cartridge this is more than likely to be the cause. If the cold water and hot water seats have been damaged, they must be replaced Have you checked to make sure the pressure is to manufacturer's recommendations and in line with the plumbing code Ensure you have adequate pressure on both hot and cold Temperature difference must be within tolerances
What parts do I need to replace and when	<ul style="list-style-type: none"> Preventing issues 	<ul style="list-style-type: none"> The full cartridge must be replaced every 5 years, however in the event the cartridge is having any issues in between the 5 year period, we recommend that the cartridge be replaced
Issue with water flow	<ul style="list-style-type: none"> Not enough water Too much / little water 	<ul style="list-style-type: none"> Check for blockages in the inlet where the strainer is fitted, or if the aerators are blocked with debris Is the isolating valve fully open on both hot and cold Have got these in a bank, if so, is the inlet pipes been sized correctly Has the laminar flow control been installed High pressure exceeding the plumbing code will have an effect on the product and must not exceed 500kPa
Not enough water	<ul style="list-style-type: none"> Taps installed in a bank or a trough 	<ul style="list-style-type: none"> Ensure the main pipe size is sized correctly to ensure adequate water is able to service the taps installed in a bank or a trough

Problem	Cause	How to Fix
The tap or valve is leaking	<ul style="list-style-type: none"> Debris 	<ul style="list-style-type: none"> Have you flushed your water lines If rubbish has gone through the cartridge, there is a high chance you will need to replace the cartridge or the parts in the valve
No water	<ul style="list-style-type: none"> Isolating valve is off 	<ul style="list-style-type: none"> Ensure the isolating valve is turned on
How often do I need to service my tap	<ul style="list-style-type: none"> Prevent product failure 	<ul style="list-style-type: none"> Service and maintenance of the main operating parts is recommended as this will prolong the life of the product

Water Quality

Maximum chloride Cl- level Guidelines in plumbing systems

	Cold Water	Hot Water
Grade 304L	200	50
Grade 316L	1000	250

When materials may be used in either hot or cold water lines, the guidelines for hot water should be used.

Within these guidelines at ambient temperatures and provided the pH >~6, any negative effect to stainless steel will be unlikely.

Note: Chlorides in water - where the density of the solvent (water) is 1 (which it is to within 0.1% at ambient temperatures), then mg/L = ppm.

For brass products, please ensure the chlorine and chloramines levels are not more than 0.4 ppm.

Please ensure that the water quality supplied to the fixtures meets safe drinking standards to prevent potential staining of the product.

Chlorine guidelines (not to be confused with chloride)

- 304L suitable for chlorine levels up to 2ppm.
- 316L suitable for chlorine levels up to 5ppm.
- Short term dosing, for example 25-50ppm, for sterilisation purposes of 24-48 hours acceptable if effectively flushed through afterwards.
- Sterilisation is essential during commissioning of potable water systems.

Reference: <https://www.assda.asn.au/component/content/article?id=271:chlorine-and-chloride--same-element,-very-different-effect>

USER MANUAL

Responsibly Sourced



Reduce Carbon Footprint

GENTEC is rejuvenating the product- no power, less maintenance and longer life.

Rejuvenation Program

To learn more about the rejuvenation program, please contact our customer service at info@gentecaustralia.com.au for more information.

Ethically and Environmentally Sourced

Please refer to GENTEC Business Ethics & Ethical Sourcing Policy at <https://gentecaustralia.com.au/terms-and-conditions/>

Commissioning Report

TEMPSET Thermostatic Mixing Tap Commissioning Report. This report is only relevant to the TEMPSET range.

Project Name / Installation:	
Address:	
Date:	Phone:
Contact:	Email:
Address:	

Product Identification

Product Code:			
Description:			
Valves ID:			
Number of points:	Basin	Shower	Baths

Water Pressure kPa

Hot:	Cold:
------	-------

Water Temperature °C

Hot:	Cold:
------	-------

Compliant Installation YES/NO

Local Control Authority:
TMV Code of Practice:
Hosplan:
Manufacturer:

USER MANUAL

Sign off by the Contractor YES/NO

Valve has been tested and commissioned in accordance with the following:

AS 4032.4:
Hosplan:
Local Requirements:
Plumbing Code:

Commissioned by Contractor Contact Details

Date of Commission:	
Company Name:	
Contact:	
Plumber License Number:	
Plumber Signature:	
Witness by:	Date:

Valve Installation Completed by

Date of Installation:
Purchased from:
Company Name:
Contact:
Plumber License Number:
Plumber Signature:
Product Code:
Service / Warranty Manuals:

Service Report

TEMPSET Thermostatic Mixing Valve Service Report. This report is only relevant to the range.

Project Name / Installation:	
Address:	
Date:	Phone:
Contact:	Email:
Address:	

Product Identification - highlight fixtures in use

Product Code:			
Description:			
Valves ID:			
Number of points:	Basin	Shower	Baths

Water Pressure kPa

Hot:	Cold:
------	-------

Water Temperature °C

Hot:	Cold:
------	-------

Compliant Installation YES/NO

Local Control Authority:
TMV Code of Practice:
Hosplan:
Manufacturer:

USER MANUAL

Sign off by the Contractor YES/NO

Valve has been tested and serviced in accordance with the following:

AS 4032.4:
Hosplan:
Local Requirements:
Plumbing Code:

Serviced by Contractor Contact Details

Date of Service:	
Company Name:	
Contact:	
Plumber License Number:	
Plumber Signature:	
Witness by:	Date:

Valve Installation Completed by

Date of Installation:
Purchased from:
Company Name:
Contact:
Plumber License Number:
Plumber Signature:
Product Code:
Service / Warranty Manuals:



A: Unit 6, 20-28 Ricketty St,
Mascot, Sydney, NSW 2020

E: info@gentecaustralia.com.au

P: +612 9319 4422

F: +612 8088 7635

Gentec products come with a Manufacturer's Warranty. To ensure the validity of this warranty, Gentec products must be installed following the provided installation instructions and adhering to AS 3500, NCC Volume Three, relevant Australian Standards, and any local authority requirements applicable to the product. Additionally, water and electrical supply conditions must meet the appropriate national and/or state standards. Non-compliance with these provisions may void the warranty and impact product performance.

Note: The information provided is only a guide, actual product may differ. The information here should not be relied on without clarification with Gentec. Gentec reserves the right to make design changes at any time without notification.

*Subject to terms and conditions. For detailed warranty information, installation compliance, maintenance and cleaning guidelines, and other relevant details, please visit <https://gentecaustralia.com.au>

gentecaustralia.com.au