

USER MANUAL

GPURE® SMARTEC PLUS Stainless Steel Electronic Sensor Taps & Sensor Plates



- **PLUS1000 (M/B/BM)** - Zero Lead Stainless Steel 316 Hob Mounted 90 Degree Electronic Tap w/ Laser Sensor
- **PLUS2500 (M/B/BM)** - Zero Lead Stainless Steel 316 Wall Mounted Electronic Tap w/ Laser Sensor
- **PLUS3500 (M/B/BM)** - Zero Lead Stainless Steel 304 Wall Mounted Electronic Sensor Plate w/ Spout Less Laser Sensor
- **PLUS4500 (M/B/BM)** - Zero Lead Stainless Steel 304 Wall Mounted Electronic Plate w/ Magnetized Concealed Fixing Laser Sensor Battery & Mains Powered



M: Mains Powered

B: Proprietary Battery Powered

BM: Battery & Mains Powered

Disclaimer: Stainless Steel Grades 304 & 316 are manufactured with ZERO Lead.



gentecaustralia.com.au

USER MANUAL

Table of Contents

Scope of Use	2
Technical Information	3
Product Images & Technical Drawings	4
Exploded Drawings	6
Installation Steps	8
Troubleshooting	15
Cleaning & Maintenance	17
Spare Parts	17
Water Quality	18
Responsibly Sourced	18

Scope of Use

Installation of all products should adhere to the manufacturer's guidelines, as well as comply with PCA, AS/NZS3500 standards, and any other relevant regulatory provisions. This product range complies with the Lead Free requirements of the National Construction Code Volume Three.

- **Installation:** Refer to the installation instructions included within this manual
- **Water quality:** In line strainer (supplied) must be installed to ensure water quality
- **Suitable for indoor use only**
- **Temperature recommendation:**
 - Single temperature mixed up to 42°C
 - Minimum temperature: 5°C
- **Power voltage:** 6V AC / DC (battery and mains)
- **Sensor:** Laser technology
- **Mounting:** Wall, bench or in line installation

Technical Information

Material	<ul style="list-style-type: none"> • PLUS1000 (M, B, BM), PLUS2500 (M, B, BM): (Main Body: Zero Lead Stainless Steel 304, Internal System: Zero Lead Stainless Steel 316) • PLUS3500 (M, B, BM), PLUS4500 (M, B, BM): Zero Lead Stainless Steel 304
Cartridge	Solenoid Valve
Cartridge Size	15 mm
Inlet	<ul style="list-style-type: none"> • PLUS1000 (M, B, BM): 15 mm Female Flexible Connections • PLUS2500 (M, B, BM), PLUS3500 (M, B, BM), PLUS4500 (M, B, BM): 15mm Male
Flow Style	PLUS1000 (M, B, BM), PLUS2500 (M, B, BM): Laminar Flow
Run time	<ul style="list-style-type: none"> • PLUS1000 (M, B, BM), PLUS2500 (M, B, BM): 2 seconds (auto on / off) • PLUS3500 (M, B, BM): 15 seconds (Factory Adjustable) • PLUS4500 (M, B, BM): Auto On/Off
Working Pressure	50kPa-500kPa
Manufacturers Recommended Pressure	350 kPa
Working Temperatures	5°C - 50°C
Finish	<ul style="list-style-type: none"> • PLUS1000 (M, B, BM), PLUS2500 (M, B, BM): Polished • PLUS3500 (M, B, BM), PLUS4500 (M, B, BM): Brushed
Servicing	Preventative Maintenance

USER MANUAL

Product Images & Technical Drawings

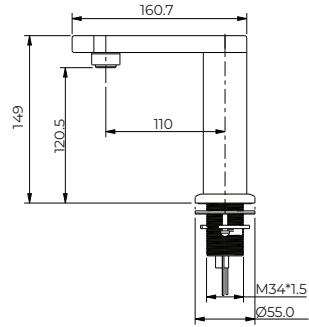

PLUS1000

BM - Zero Lead Stainless Steel 316 Hob Mounted 90 Degree Electronic Tap w/ Laser Sensor Battery & Mains Powered

B - Zero Lead Stainless Steel 316 Hob Mounted 90 Degree Electronic Tap w/ Laser Sensor Proprietary Battery Powered

M - Zero Lead Stainless Steel 316 Hob Mounted 90 Degree Electronic Tap w/ Laser Sensor Mains Powered

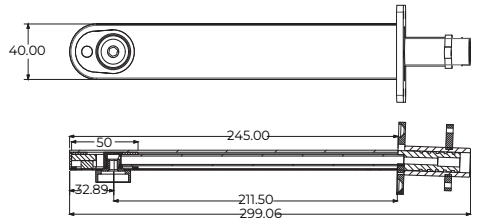

PLUS2500

BM - Zero Lead Stainless Steel 316 Wall Mounted Electronic Tap w/ Laser Sensor Battery & Mains Powered

B - Zero Lead Stainless Steel 316 Wall Mounted Electronic Tap w/ Laser Sensor Proprietary Battery Powered

M - Zero Lead Stainless Steel 316 Wall Mounted Electronic Tap w/ Laser Sensor Mains Powered

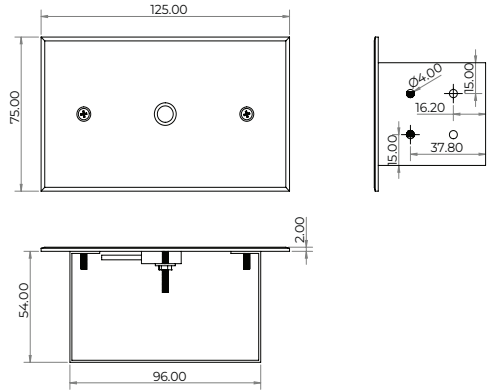

PLUS3500

BM - Zero Lead Stainless Steel 304 Wall Mounted Electronic Sensor Plate w/ Spout Less Laser Sensor Battery & Mains Powered

B - Zero Lead Stainless Steel 304 Wall Mounted Electronic Sensor Plate w/ Spout Less Laser Sensor Proprietary Battery Powered

M - Zero Lead Stainless Steel 304 Wall Mounted Electronic Sensor Plate w/ Spout Less Laser Sensor Mains Powered

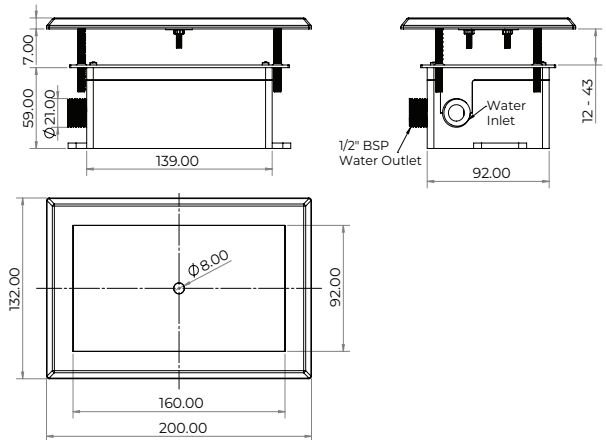

PLUS4500

BM - Zero Lead Stainless Steel 304 Wall Mounted Electronic Plate w/ Magnetized Concealed Fixing Laser Sensor Battery & Mains Powered

B - Zero Lead Stainless Steel 304 Wall Mounted Electronic Plate w/ Magnetized Concealed Fixing Laser Sensor Proprietary Battery Powered

M - Zero Lead Stainless Steel 304 Wall Mounted Electronic Plate w/ Magnetized Concealed Fixing Laser Sensor Mains Powered

Note: Dimensions are provided as a guide and are subject to manufacturing tolerances.

USER MANUAL

Exploded Drawings

PLUS1000BM

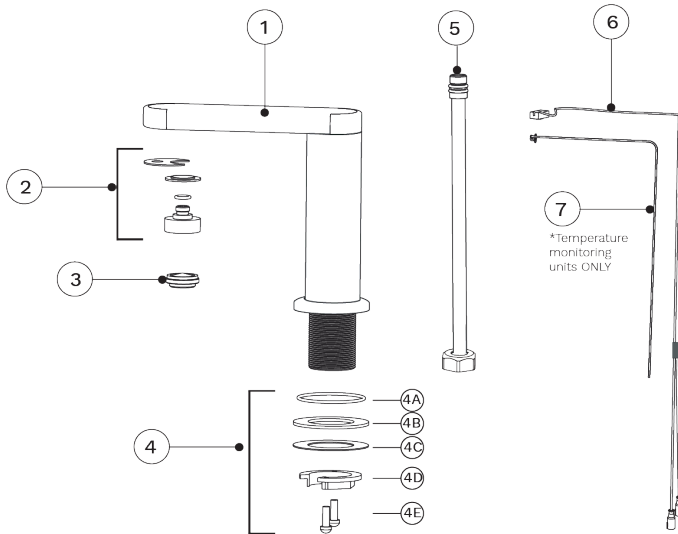

Item#	Description	Qty	Spare Parts
1	Tap Body	1	<input type="checkbox"/>
2	Aerator housing/cover	1	<input type="checkbox"/>
3	Aerator	1	<input checked="" type="checkbox"/>
4	Fixing kit	1	<input type="checkbox"/>
4A	O-Ring	1	<input type="checkbox"/>
4B	Washer	1	<input type="checkbox"/>
4C	Fixing Plate	1	<input type="checkbox"/>
4D	Fixing Nut	1	<input type="checkbox"/>
4E	Screws	2	<input type="checkbox"/>
5	Flexible Hose	1	<input type="checkbox"/>
6	Sensor* Preventative Maintenance	1	<input checked="" type="checkbox"/>
7	Temperature Probe	**	<input type="checkbox"/>

Note:

*To minimise product downtime, we recommend that you regularly check these items.

** Not all spare components are available for individual sale. Contact GENTEC for more information.

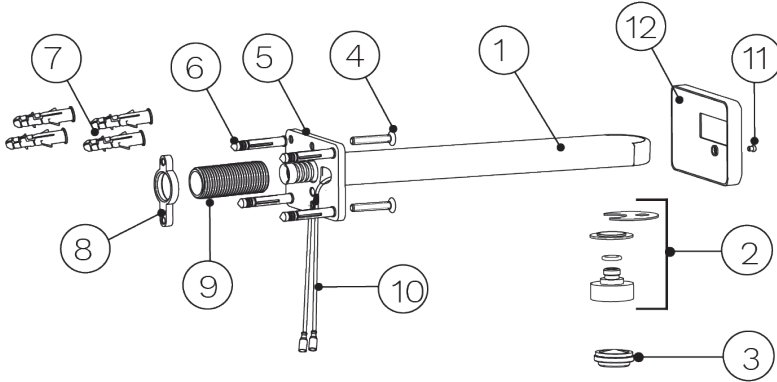
PLUS2500BM

Item#	Description	Qty	Spare Parts
1	Tap Body	1	<input type="checkbox"/>
2	Aerator housing/cover	1	<input type="checkbox"/>
3	Aerator	1	<input type="checkbox"/>
4	Hex Screws	2	<input type="checkbox"/>
5	Spout Flange	1	<input type="checkbox"/>
6	Mounting Screws	4	<input type="checkbox"/>
7	Wall Plugs	4	<input type="checkbox"/>
8	Back Nut	1	<input type="checkbox"/>
9	Threaded Piece	1	<input type="checkbox"/>
10	Sensors* Preventative Maintenance	1	<input checked="" type="checkbox"/>
11	Grub Screw	1	<input type="checkbox"/>
12	Flange	1	<input type="checkbox"/>

Note:

*To minimise product downtime, we recommend that you regularly check these items.

USER MANUAL

Installation Steps

PLUS1000BM & PLUS2500BM GENERAL CONNECTIONS

Screw the solenoid box to the wall using the screws provided.
Ensure to have enough space between the wall and the fixing point.

BM: Battery and Mains Operated
B: Battery Operated
M: Mains Operated

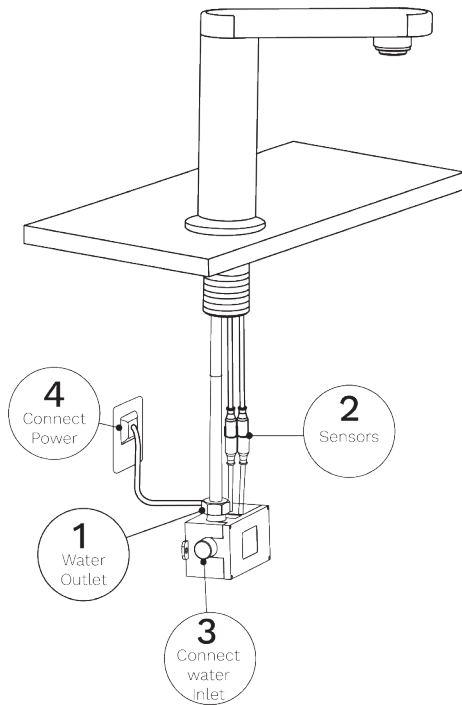

When using the unit for first time

- Make sure to turn the power first and then the water supply.
- Lines must be flushed before installation.

- Step 1. Remove washers and back nut from the tap.
- Step 2. Screw in flexi hose to the tap.
- Step 3. Place tap through the pre-punched hole in the basin.
- Step 4. From underneath, place washers and back nut and tighten, secure the tap by tightening the 3 locking screws.

- Step 5. Connect the tap flexible hose to the power control box outlet. Make sure the connections are firm and in the right place. At this point, fasten the solenoid box to the wall.

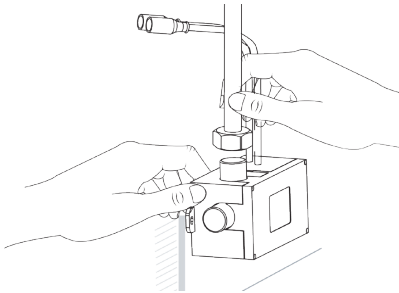

- Step 6. Connect the tap sensor wires (1m length) onto the solenoid box matching the cables by colour.

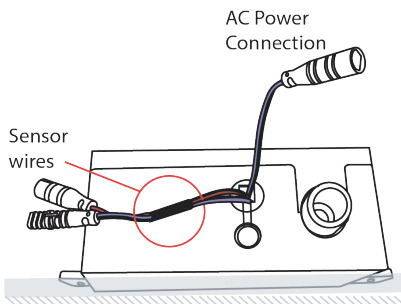
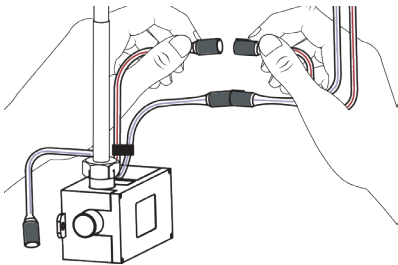

2m extension cables are available if required. The extension can be used either for the sensor or for the power. Not for extending both.

- Step 7. Connect the water supply to the solenoid box inlet.

- Step 8. Plug in the solenoid box. **Make sure to turn the power first and then the water supply.**

When the unit is powered on, water should flow immediately when you put your hands within range of the sensor.

When you remove your hands out of range, water should stop within 2 seconds.

The maximum duration of continuous flow is 1 minute.

BATTERY CHANGE

- Step 1. In case you have plugged in the mains, disconnect power and open the cover of the control box, open the battery holder, remove the batteries and replace all batteries with new ones.

- Step 2. Please install the batteries in the right direction, the + and – side are indicated in the battery holder.

- Step 3. Close the battery holder, place the cover back in place and tighten the screws.

USER MANUAL

PLUS1000BM & PLUS2500BM SENSITIVITY ADJUSTMENT

Step 1. The sensor's maximum distance is 170mm.

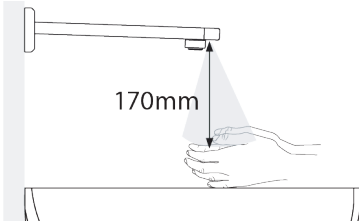

Step 2. To reprogram sensitivity disconnect the sensor power cable from the solenoid box and leave it for at least 20 seconds.

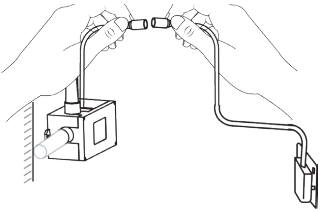

Step 3. Connect power cable again and wait for the sensor light to start flashing. Immediately, place your finger on the sensor until the light becomes solid. This allows the sensor to enter in reprogramming mode.

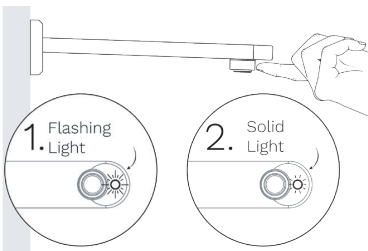

Step 4. Place your hand to the desired position to adjust sensitivity and hold it in position until the light turns off.

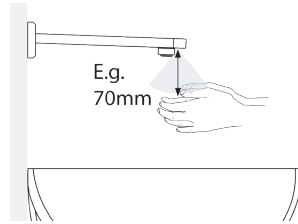

Step 5. To set the sensor at maximum distance, disconnect the power cable from the solenoid box, and **repeat step 3** to enter in reprogramming mode.

Do not place anything in front of the sensor and allow the light to turn off.

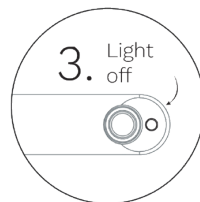
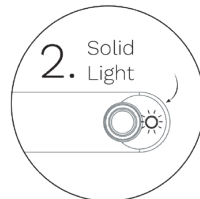
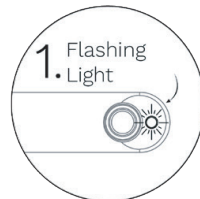

PLUS1000BM MOUNTING INSTRUCTIONS

Step 1. Flush the new pipe prior to installation.

Step 2. Drill a 35mm hole on the counter top.

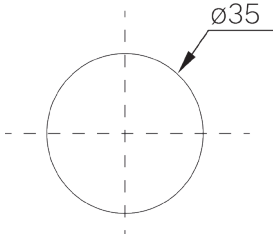

Step 3. Remove rubber seal, fixing plate and fixing nut from the tap and screw in the flexi hose.

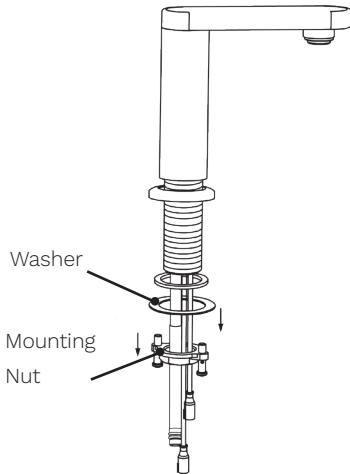

Step 4. Place the Flange, and insert the sensor cable followed by the flexi hose through the tap hole in the counter top.

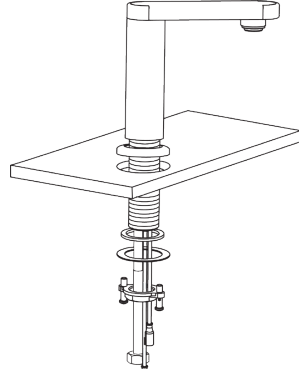

Step 5. From underneath the sink or basin, fix rubber seal, fixing plate and fixing nut with a spanner. Make sure the screws are well tightened to the counter top.

Step 6. Plug in sensor to solenoid box (See page 8 for complete installation of Solenoid).

Important Information

- Switch power on solenoid box first and test electronics before turning on water supply.

USER MANUAL

PLUS2500BM IN WALL FIT OUT

- Step 1. Remove the threaded piece (9) using a 3mm Allen Key.

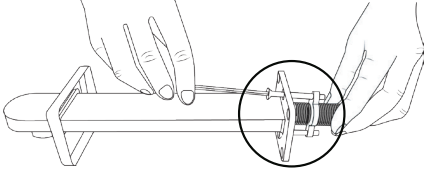

- Step 2. Remove the threaded back nut (8) completely. *Not needed for this installation.

- Step 3. Allow a 15mm (minimum) conduit for easy installation of the sensor wires. Individual installation may vary. See Figure 1 below *Contact Gentec for installation advise.

- Step 4. Apply adequate thread tape and screw on the threaded piece into the female plumbing fitting in the wall. Use the 2 flats to tighten with correct spanner.

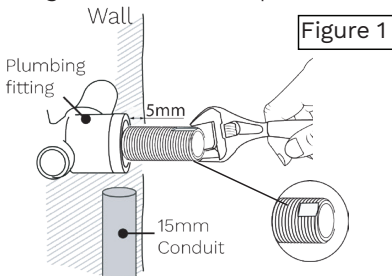

- Step 5. Feed the sensor wires through the conduit and push the tap body through the threaded piece (9).

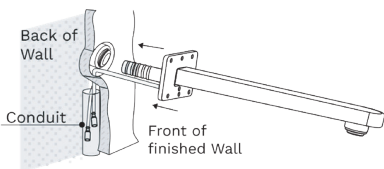

- Step 6. Use the Spout flange to mark out the 4 mounting screw holes.

- Step 7. Fix the screws and tighten.

- Step 8. Slide over the cover flange and secure with single screw provided.

BATTERY CHANGE

- Step 1. In case you have plugged in the mains, disconnect power and open the cover of the control box, open the battery holder, remove the batteries and replace all batteries with new ones.

- Step 2. Please install the batteries in the right direction, the + and - side are indicated in the battery holder.

- Step 3. Close the battery holder, place the cover back in place and tighten the screws.

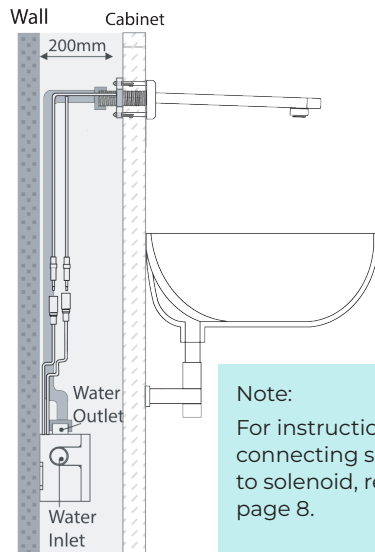

Note:
For instructions on connecting sensor to solenoid, refer to page 8.

PLUS4500B/BM/M INSTALLATION INSTRUCTIONS

Before Installation

Before connecting water to the valve, ensure to flush the line and remove all debris.

All fixtures must be installed using slim compression fittings.

Working pressure must be between 150 and 450kPa.

Item#	Description	Qty
1	Solenoid Box	1
2	Backing Plate	1
3	Sensor Plate	1
4	Cover Plate	1

Back of Wall Installation

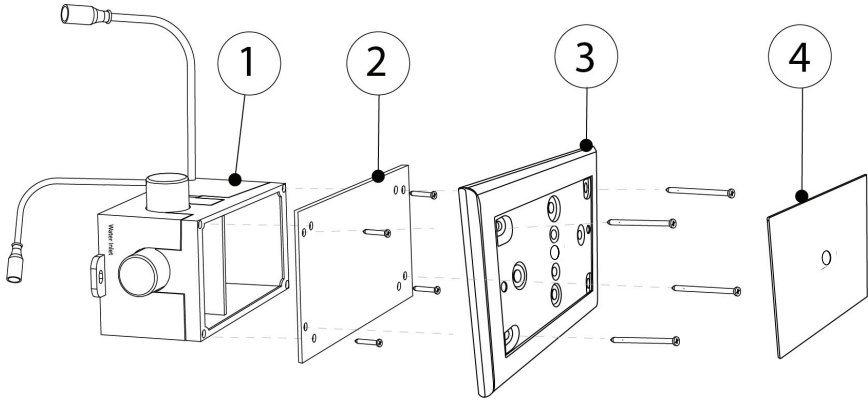

Step 1. Remove the plastic lid from the solenoid box (1).

Step 2. Allow a straight line cut 190mm (width) x 120mm (height) in the wall 70mm to 110mm deep.

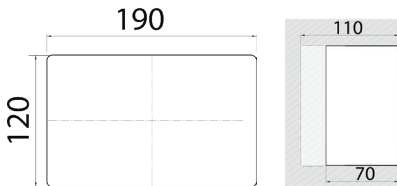

Step 3. Connect the sensor cable from the sensor plate (3) to the solenoid box (1) and the battery / power transformer.

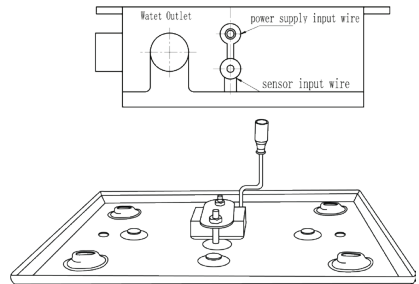

USER MANUAL

- Step 4. Connect all plumbing before mounting the solenoid box to the wall using the screws provided.

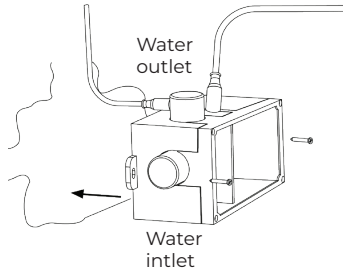

- Step 5. Use the screws provided to mount the backing plate (2) onto the solenoid box (1).

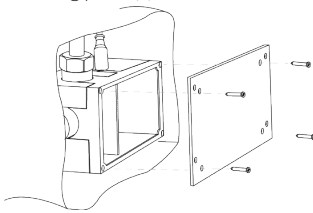

Front of Wall Installation

- Step 6. Install the sensor plate by tightening the screws provided equally. Fix the top screws first to ensure the plate is straight. Note the screws have up to 45mm adjustment.
- Step 7. Place the cover plate (4) to the sensor plate (3). Ensure the black mark on the back of cover plate in line with the black mark on sensor plate hole. Use a suction cup to remove the magnetic cover plate if required.

Important information

Plug in the power adaptor first and test electronics before turning on the water supply.

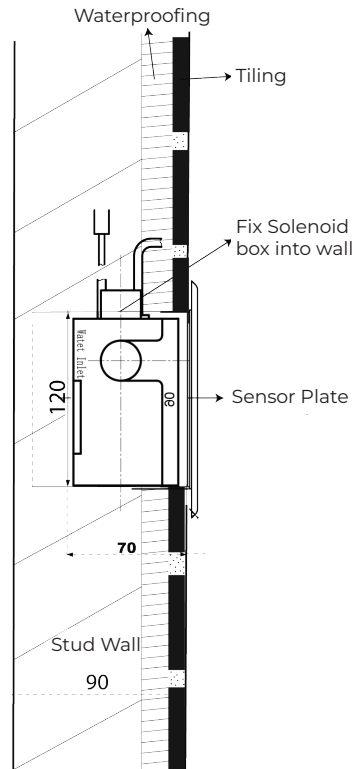

Important : Please do not throw out the suction cup.

Troubleshooting

Problem	Cause	How to Fix
Tap is not shutting off	<ul style="list-style-type: none"> • Debris • Power connections 	<ul style="list-style-type: none"> • Is the power connected • Did you turn the power on then the water, if you didn't do that, then start the process again, turn the power and water off • Have you flushed the water line for a minimum of 1 minute before connecting the water • Have you installed the strainer and flow controller if provided • If debris is in the solenoid, then it must be cleaned out and if it's still a problem, it must be replaced, debris may have had affected the seat causing the item to leak • Have you checked to make sure the pressure is to manufacturer's recommendations and in line with the plumbing code • Ensure there is power from the power point
No power	<ul style="list-style-type: none"> • Electricity not on 	<ul style="list-style-type: none"> • Check power is connected and on • Ensure the lights come on the sensor, if not then power is not connected and or not plugged in correctly • Make sure the lights come on the sensor • If light don't come on the sensor, it could be power related • If all the above is ok, it may require a new sensor
Run cycle not right	<ul style="list-style-type: none"> • Need to be re-programmed 	<ul style="list-style-type: none"> • Product is factory set to run on when your hands have activated the sensor • Changing programs, have you got a remote, if not, then you need a remote and the instructions to adjust the program to suit your needs

USER MANUAL

Problem	Cause	How to Fix
Issue with water flow	<ul style="list-style-type: none">• Not enough water• Too much / little water	<ul style="list-style-type: none">• Check for blockage• Is the isolating valve fully open• Have got these in a bank, if so, is the inlet pipes been sized correctly• Has the flow control been installed• Pressure is too high, max inlet water pressure is 500kPa but manufacturer's recommended pressure is 350kPa• If the flexi hose is used, ensure it's not kinked/twisted
How often do I need to service my tap	<ul style="list-style-type: none">• Prevent product failure	<ul style="list-style-type: none">• Service and maintenance of the main operating parts is recommended as this will prolong the life of the product

Cleaning & Maintenance

To minimise downtime and maximise the functional life of the product, GENTEC recommends servicing your product at least every 12 months, under heavy use may need to be checked and serviced more often.

- The product must be handled carefully to avoid causing any physical damage.
- Use the product at least once every week to ensure all parts are kept lubricated and functioning properly.
- Service the product at least once a year to avoid any product failures - The service timeline provided is based on normal use. More frequent servicing may be required for heavy usage.
- The service timeline provided is based on the normal use. More frequent service may be required for hard usages.
- A working pressure of 350kPa is highly recommended to ensure the maximum up-time of the product.
- Regularly clean the product with a soft cloth with warm soapy water, wash off with warm water and dry off with a soft dry cloth, paying attention to removing the dust and contamination in the bends and joints is highly recommended.
- Abrasives, hard clothes, strong acids, and bleaches must be avoided when cleaning all GENTEC products.
- Installation must be completed by a qualified and licenced plumber and adhere to AS/NZS3500 and manufacturer's recommendations.

Spare Parts

Parts	Product Name
PLUS10PP	PLUS / BAC power transformer only
PLUS10BP	PLUS battery pack only
PLUS10CX2	PLUS control box with solenoid
PLUSLEADSS	PLUS 2m sensor extension lead (to suit PLU10CX2 connection to sensor or main power)
PLUS9003	PLUS tap sensor only to suit PLUS1000/PLUS2500
AEM24-1.9S	Aerator M24-1.9 7pm slim spray pattern flow (to suit PLUS/GPG range)
AEM24-5.6	Aerator M24-5.6 7pm slim / swivel (to suit PLUS)

USER MANUAL

Water Quality

Maximum chloride Cl- level Guidelines in plumbing systems

	Cold Water	Hot Water
Grade 304L	200	50
Grade 316L	1000	250

When materials may be used in either hot or cold water lines, the guidelines for hot water should be used.

Within these guidelines at ambient temperatures and provided the pH >~6, any negative effect to stainless steel will be unlikely.

Note: Chlorides in water - where the density of the solvent (water) is 1 (which it is to within 0.1% at ambient temperatures), then mg/L = ppm.

For brass products, please ensure the chlorine and chloramines levels are not more than 0.4 ppm.

Please ensure that the water quality supplied to the fixtures meets safe drinking standards to prevent potential staining of the product.

Chlorine guidelines (not to be confused with chloride)

- 304L suitable for chlorine levels up to 2ppm.
- 316L suitable for chlorine levels up to 5ppm.
- Short term dosing, for example 25-50ppm, for sterilisation purposes of 24-48 hours acceptable if effectively flushed through afterwards.
- Sterilisation is essential during commissioning of potable water systems.

Reference: <https://www.assda.asn.au/component/content/article?id=271:chlorine-and-chloride--same-element,-very-different-effect>

Responsibly Sourced



Reduce Carbon Footprint

GENTEC is rejuvenating the product- no power, less maintenance and longer life.

Rejuvenation Program

To learn more about the rejuvenation program, please contact our customer service at info@gentecaustralia.com.au for more information.

Ethically and Environmentally Sourced

Please refer to GENTEC Business Ethics & Ethical Sourcing Policy at <https://gentecaustralia.com.au/terms-and-conditions/>



A: Unit 6, 20-28 Ricketty St,
Mascot, Sydney, NSW 2020

E: info@gentecaustralia.com.au

P: +612 9319 4422

F: +612 8088 7635

Gentec products come with a Manufacturer's Warranty. To ensure the validity of this warranty, Gentec products must be installed following the provided installation instructions and adhering to AS 3500, NCC Volume Three, relevant Australian Standards, and any local authority requirements applicable to the product. Additionally, water and electrical supply conditions must meet the appropriate national and/or state standards. Non-compliance with these provisions may void the warranty and impact product performance.

Note: The information provided is only a guide, actual product may differ. The information here should not be relied on without clarification with Gentec. Gentec reserves the right to make design changes at any time without notification.

*Subject to terms and conditions. For detailed warranty information, installation compliance, maintenance and cleaning guidelines, and other relevant details, please visit <https://gentecaustralia.com.au>

gentecaustralia.com.au