

USER MANUAL

GPURE® FLOSTOP Stainless Steel Bubblers & Bottle Fillers



- **GPT8000** - Zero Lead Stainless Steel 316 Wall Mounted Right Angled Single Temperature Timed Flow Bubbler w/ Safety Bubbler Guard
- **GPT8050** - Zero Lead Stainless Steel 316 Wall Mounted Angled Single Temperature Timed Flow Bubbler w/ Safety Bubbler Guard
- **GPT8050UR** - Zero Lead Stainless Steel 316 Hob Mounted Upright Single Temperature Timed Flow Bubbler w/ Safety Bubbler Guard
- **GPT8100** - Zero Lead Stainless Steel 316 Wall Mounted Single Temperature Timed Flow, Gooseneck Spout Bottle Filler
- **GPT8200** - Zero Lead Stainless Steel 316 Hob Mounted Upright Single Temperature Timed Flow, Gooseneck Spout Bottle Filler



Disclaimer: Stainless Steel Grade 316 is manufactured with ZERO Lead.

gentecaustralia.com.au

USER MANUAL

Table of Contents

Scope of Use	2
Technical Information	3
Exploded Drawings	4
Product Images & Technical Drawings	6
Installation Steps	8
Time Adjustment	11
Water Flow Adjustment	12
Cleaning & Maintenance	13
Troubleshooting	15
Water Quality	16
Responsibly Sourced	17

Scope of Use

Installation of all products should adhere to the manufacturer's guidelines, as well as comply with PCA, AS/NZS3500 standards, and any other relevant regulatory provisions. This product range complies with the Lead Free requirements of the National Construction Code Volume Three.

- **Installation:** Refer to the installation instructions included within this manual
- **Water quality:** In line strainer (supplied) must be installed to ensure water quality
- **Suitable for indoor and outdoor use**
- **Temperature recommendation:**
 - Single temperature up to 50°C
 - Dual temperature up to 80°C
 - Minimum temperature: 5°C
- **Mounting:** Wall, bench or in line installation

Technical Information

Body Material	Stainless Steel (SS316)
Bubbler Guard Material	GPT8000, GPT8050, GPT8050UR only: UV Stabilised Food Grade Rubber
Cartridge	Timed Flow (Hydraulic)
Cartridge Size	15mm
Inlet	15mm Female (G 1/2" BSP)
Outlet	Free Flow (Adjustable)
Run Time	2-40 (+/-5) seconds (Adjustable)
Working Pressure	150kPa-500kPa
Manufacturers Recommended Pressure	350 kPa
Working Temperature	5°C - 50°C
Finish	Brushed Stainless Steel
Servicing	Preventative Maintenance

USER MANUAL

Exploded Drawings

Bubblers

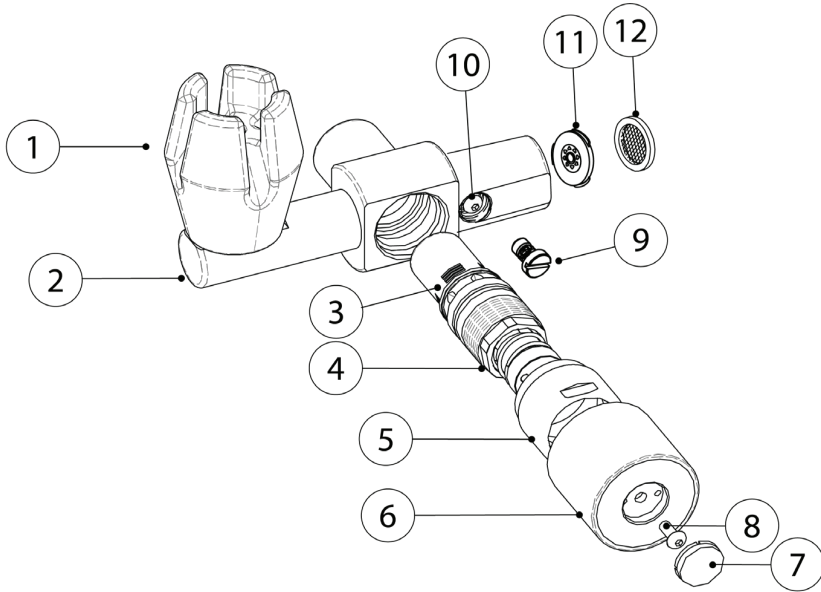

Item#	Description	Qty	Spare Parts
1	Bubbler Guard	1	<input type="checkbox"/>
2	Body	1	<input type="checkbox"/>
3	Flow Cup	1	<input checked="" type="checkbox"/>
4	Cartridge	1	<input checked="" type="checkbox"/>
5	Cover Flange	1	<input type="checkbox"/>
6	Handle	1	<input checked="" type="checkbox"/>
7	Indicator	1	<input checked="" type="checkbox"/>
8	Cover Screw	1	<input checked="" type="checkbox"/>
9	Locking Screw	1	<input type="checkbox"/>
10	Flow Adjustment Screw	1	<input type="checkbox"/>
11	Flow Regulator	1	<input checked="" type="checkbox"/>
12	Strainer	1	<input checked="" type="checkbox"/>
13	O-Ring Kit	Preventative Maintenance	<input checked="" type="checkbox"/>

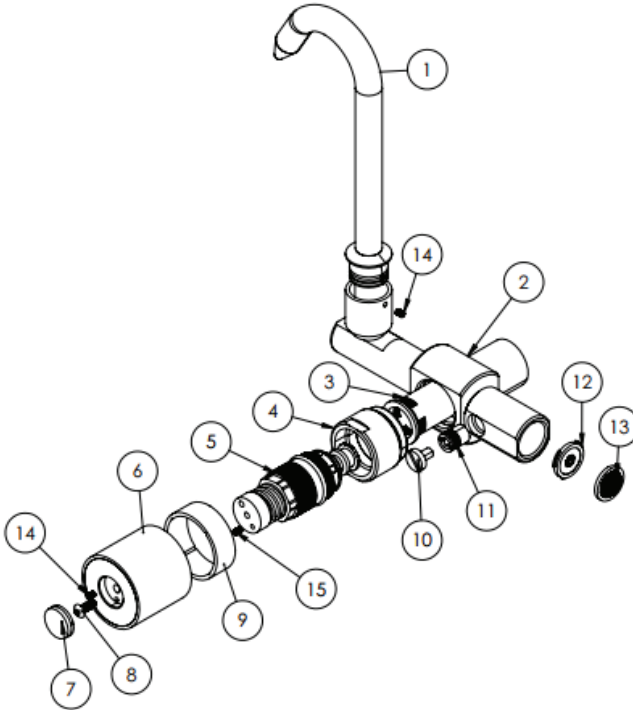
Bottle Fillers

Item#	Description	Qty	Spare Parts
1	Gooseneck Spout	1	<input type="checkbox"/>
2	Body	1	<input type="checkbox"/>
3	Flow Cup	1	<input checked="" type="checkbox"/>
4	Cover Flange	1	<input type="checkbox"/>
5	Cartridge	1	<input checked="" type="checkbox"/>
6	Handle	1	<input checked="" type="checkbox"/>
7	Indicator	1	<input checked="" type="checkbox"/>
8	Cover Screw	1	<input type="checkbox"/>
9	Indicator	1	<input checked="" type="checkbox"/>
10	Locking Screw	1	<input checked="" type="checkbox"/>
11	Flow Adjustment Screw	1	<input type="checkbox"/>

Item#	Description	Qty	Spare Parts
12	Flow Regulator	1	<input checked="" type="checkbox"/>
13	Strainer	1	<input checked="" type="checkbox"/>
14	Grub Screw (Fixing)	1	<input type="checkbox"/>
15	Grub Screw (Adjustment)	1	<input type="checkbox"/>
16	O-Ring Kit	1	<input checked="" type="checkbox"/>
	Preventative Maintenance		<input checked="" type="checkbox"/>

USER MANUAL

Product Images & Technical Drawings

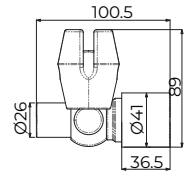
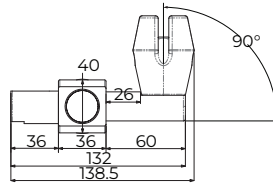
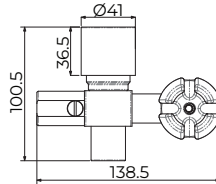

GPT8000

Zero Lead Stainless Steel 316 Wall Mounted Right Angled Single Temperature Timed Flow Bubbler w/ Safety Bubbler Guard

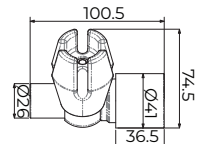
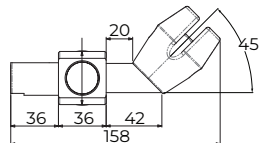
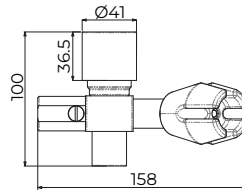
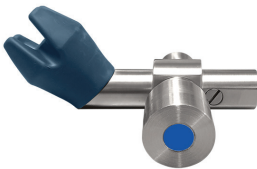

GPT8050

Zero Lead Stainless Steel 316 Wall Mounted Angled Single Temperature Timed Flow Bubbler w/ Safety Bubbler Guard

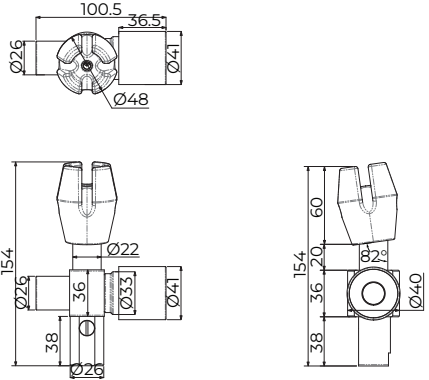

GPT8050UR

Zero Lead Stainless Steel 316 Hob Mounted Upright Single Temperature Timed Flow Bubbler w/ Safety Bubbler Guard

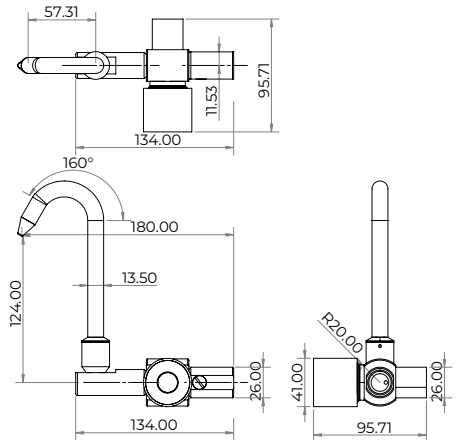

GPT8100

Zero Lead Stainless Steel 316 Wall Mounted Single Temperature Timed Flow, Gooseneck Spout Bottle Filler

Note: Dimensions are provided as a guide and are subject to manufacturing tolerances.

USER MANUAL

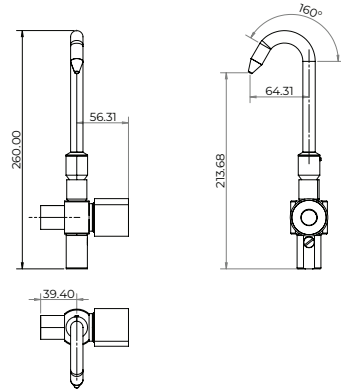

GPT8200

Zero Lead Stainless Steel 316 Hob Mounted Upright Single Temperature Timed Flow, Gooseneck Spout Bottle Filler

Installation Steps

BUBBLERS INSTALLATION STEPS

Step 1. Flush the water supply pipework prior to installation.

Step 2. It is recommended that an isolating valve be installed to facilitate ease of maintenance.

Step 3. Install the Flow regulator and place the strainer in the inlet connection before screwing the bubbler to the water inlet.

Note : Ensure the flow regulator is facing the correct direction.

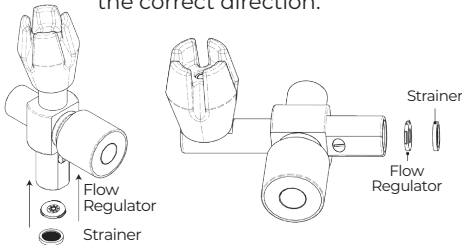

Step 4. Apply adequate thread tape to the water inlet supply.

Step 5. Connect the bubbler to the water supply.

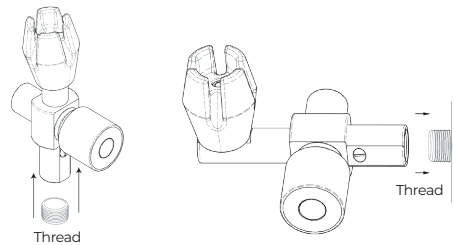

Important Information

We do not recommend dismantling the internal parts of the bubbler. The bubbler is factory assembled and tested to give the best performance.

Note: Ensure that thread sealant does not foul the bubbler inlet, strainer, flow control and timed flow headwork.

BOTTLE FILLER INSTALLATION STEPS

For both units:

- Step 1. Flush water supply pipework prior to installation.
- Step 2. It is recommended that an isolating stop valve be installed to facilitate ease of maintenance.
- Step 3. Install the Flow regulator and place the strainer in the inlet connection before screwing the bottle filler to the water inlet.
- Note : Ensure the flow regulator is facing the correct direction.

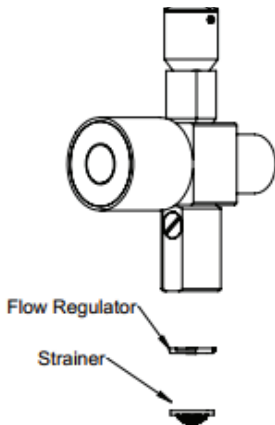
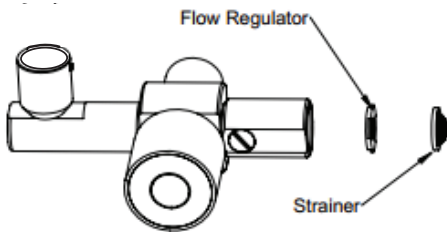

- Step 4. Apply adequate thread tape to the water inlet supply.

To secure the spout in place:

- Step 5. Insert gooseneck spout into tap body.

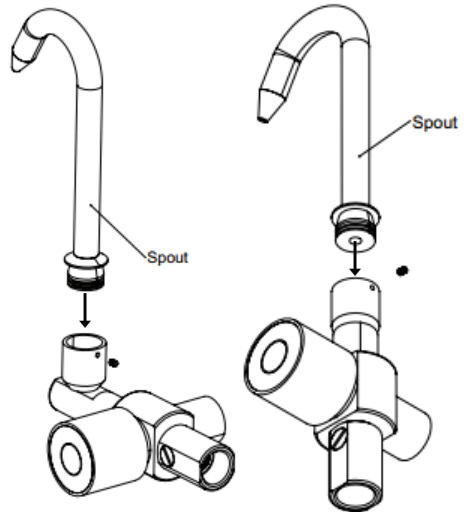

- Step 6. Tighten grub screw to secure the spout in place.

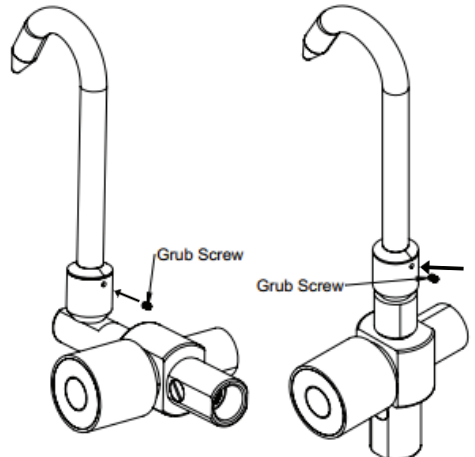

USER MANUAL

Step 7. Connect the bottle filler to the water supply.

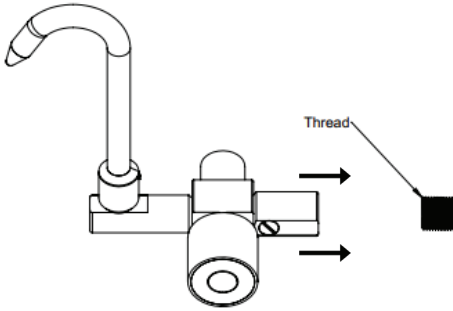

Important Information

We do not recommend dismantling the internal parts of the bottle filler. The bottle filler is factory assembled and tested to give the best performance.

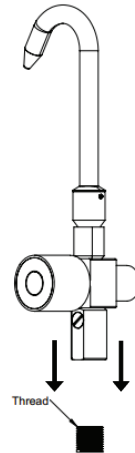

Note: Ensure that thread sealant does not foul the bottle filler inlet, strainer, flow control and timed flow headwork).

* Failure to do so may restrict or block the flow regulator affecting the flow of water.

Time Adjustment

ADJUSTABLE CARTRIDGE (2 TO 40 SECONDS)

- The run time adjustment screw is under the indicator cap. Remove the indicator cap and use a 1.5mm allen key to adjust the timing.

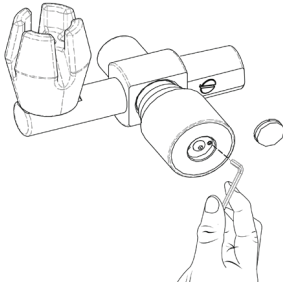

- Turning the screw clockwise will reduce the run time.

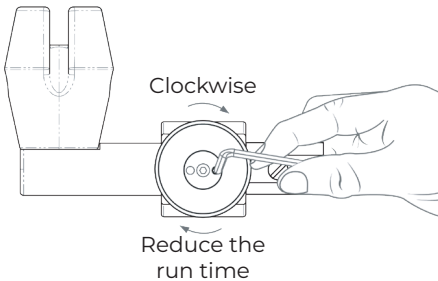

- Turning the screw anti clockwise will increase the run time.

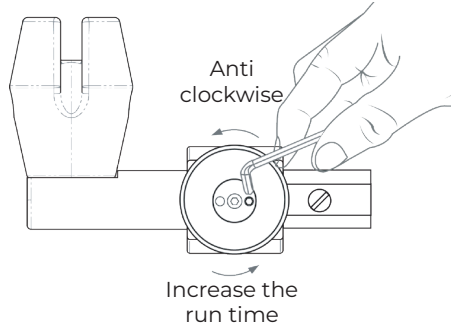

Timed Adjustment Range

Contact GENTEC before attempting to change flow cups.

Warranty may be void if damage to internal components or spare parts occurs during service / maintenance.

GPURE® is available in a range of fixed timing options which are installed ex-works.

Flow Control Cup	Description
TFT9050	Flow cup 3 - 5 +/-1 Sec
TFT9056	Flow cup 3-20 +/-5 Sec
TFT9054	Flow cup 3-40 +/-10 Sec

USER MANUAL

Water Flow Adjustment

This option is suitable for the following references: GPT8000,GPT8050, GPT8050UR, GPT8100, GPT8200.

To adjust the water flow:

Step 1. Remove the locking screw (9).

Step 2. Using a small flat blade screwdriver adjust the bubbler stream height to the desired position (Refer to schematics below).

Step 3. Replace the locking screw (9) back.

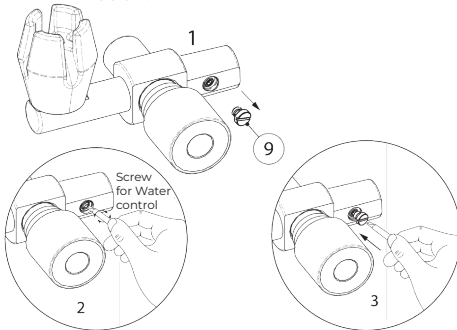

Water Pressure

In a case where multiple taps are fitted along side by side, it is important to ensure the water pressure is sufficient to service the number of taps fitted.

If the water inlet is at position A then it would require sufficient pressure to achieve the correct pressure at position D.

Use the correct pipe size to allow sufficient flow to service all units.

To lower the pressure, use 3/4" to 1" pipe.

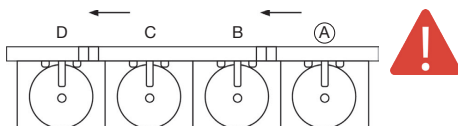

NOTE: The flow regulators will assist in the above.

- Turning the screw clockwise will reduce the water flow.

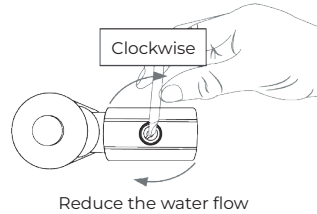

- Turning the screw anti clockwise will increase the water flow.

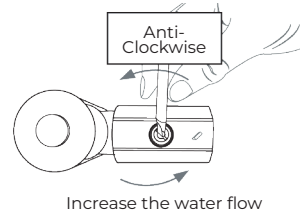

Min. Continuous Flow Working Pressure	150kPa
Max. Continuous Flow Working Pressure	450kPa
Optimum Flow Working Pressure	350kPa
Max Static Pressure	450kPa
Min. Continuous Working Temperature	5°C
Max. Continuous Working Temperature	50°C

Cleaning & Maintenance

To minimise downtime and maximise the functional life of the product, GENTEC recommends servicing your product at least every 12 months, under heavy use may need to be checked and serviced more often.

- The product must be handled carefully to avoid causing any physical damage.
- Use the product at least once every week to ensure all parts are kept lubricated and functioning properly.
- Service the product at least once a year to avoid any product failures - The service timeline provided is based on normal use. More frequent servicing may be required for heavy usage.
- A working pressure of 350kPa is highly recommended to ensure the maximum up-time of the product.
- Regularly clean the product with a soft cloth with warm soapy water, wash off with warm water and dry off with a soft dry cloth, paying attention to removing the dust and contamination in the bends and joints is highly recommended.
- Abrasives, hard clothes, strong acids, and bleaches must be avoided when cleaning all GENTEC products.
- Installation must be completed by a qualified and licenced plumber and adhere to AS/NZS3500 and manufacturer's recommendations.

Parts	Product Name
GPT9010	GPURE® FLOSTOP Cartridge only - does not include indicators
TFT9070	FLOSTOP Mesh strainer only
GPTINDKIT	GPURE® GPT Indicator kit only (red/blue/yellow)
GPT9020	GPURE® FLOSTOP top assembly of GPT8000/8050/8050UR

O-RING KIT SERVICE

Important Note

For optimum maintenance, periodically remove the bubbler from the installation, inspect and clean the strainer. If debris is present in the strainer it is recommended to flush the water supply pipework.

Service and maintenance must be undertaken by a suitably qualified plumber. Warranty may be void if damage to internal components or spare part occurs during service / maintenance.

USER MANUAL

First start by shutting off the main water supply.

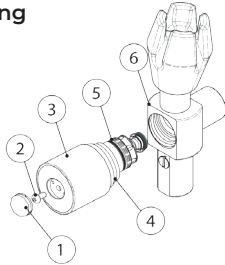

No.	Description	Qty	No.	Description	Qty
01	Indicator	1	08	Head Valve	1
02	Screw	1	09	U Cup	1
03	Handle	1	10	O-Ring	1
04	Cover Flange	1	11	Crown Ring	1
05	Cartridge	1	12	O-Ring	1
06	Body	1	13	Stopper	1
07	Stem	1	14	U Cup	1

The O-Ring Service Kit contains #7, #9 and #11

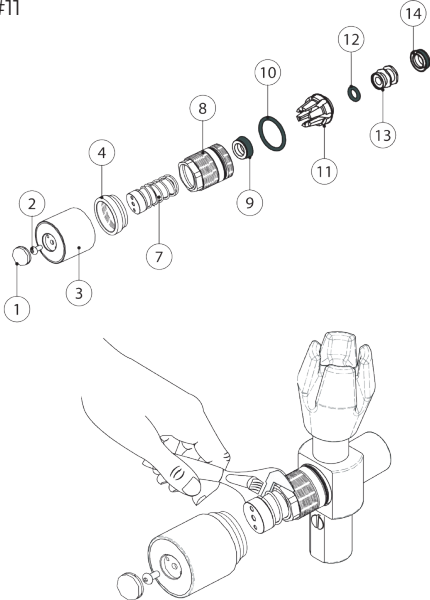

Step 1. Remove the indicator (1) using a small flat blade screwdriver, then remove the Screw (2) using a 2.5mm allen key.

Step 2. Remove the handle (3), then unscrew the cover flange (4).

Step 3. Remove the cartridge (5) using a shifter.

Step 4. Undo the stopper (13).

Step 5. Set aside the crown ring (11).

Step 6. Set aside the head valve (8) from the stem.

Step 7. Remove the U Cup (9) from the head valve (8) and replace with the new U Cup (9).

Step 8. Remove the U Cup (14) from the stopper.

Step 9. Remove the O-Ring (12) and replace it with the new O-Ring (12).

Step 10. Remove the O-Ring (10) and replace it with the new O-Ring (10).

Step 11. Using the existing crown ring (11) place it back into the head valve (8).

Step 12. Place the stem (7) through the head valve (8).

Step 13. Replace the stopper (13), ensure the O-Ring (12) is in place, then tighten the stopper (13). Do not overtighten.

Step 14. Replace the cartridge (5), cover flange and handle back into the body. Do not overtighten.

Troubleshooting

Problem	Cause	How to Fix
Tap is not shutting off	<ul style="list-style-type: none"> Debris Grease/ lubricant High pressure 	<ul style="list-style-type: none"> Is the cartridge tight Have you flushed the water line for a minimum of 1 minute before connecting the water Have you installed the strainer and flow controller if provided If debris or lubricants have gone through the flow cup, it must be replaced. Debris or lubricants have a major effect on the hydraulic cartridge, this is more than likely to be the cause Have you checked to make sure the pressure is to manufacturer's recommendations and in line with the plumbing code Gecko rubber blown/peeled over due to high pressure
No water	<ul style="list-style-type: none"> Isolating valve is off 	<ul style="list-style-type: none"> Ensure the isolating valve is turned on
Run cycle is too long	<ul style="list-style-type: none"> Need to order the right timing 	<ul style="list-style-type: none"> The standard product is not set for any set time. Customers can adjust the run time from 2 to 40 seconds If you need different timing, you will need to order and replace the flow cup If you have an adjustable time tap or valve, then you have the opportunity to adjust on site by just using an Allen key provided with every unit. The hole is located on the front of the handle, clockwise will reduce the time and anti-clockwise will increase the time
Issue with water flow	<ul style="list-style-type: none"> Not enough water Too much / little water 	<ul style="list-style-type: none"> Check for blockage Is the isolating valve fully open Have got these in a bank, if so, is the inlet pipes been sized correctly Has the flow control been installed High pressure exceeding the plumbing code will have an effect on the product and must not exceed 500kPa If flexi hose is used, ensure its not kinked/twisted
Not enough water	<ul style="list-style-type: none"> Taps installed in a bank or a trough 	<ul style="list-style-type: none"> Ensure the main pipe size is correctly sized to provide adequate water to service the taps installed in a bank or a trough

USER MANUAL

Problem	Cause	How to Fix
Knee valve and lever pillar tap won't shut off	<ul style="list-style-type: none"> The valve/ tap keeps running 	<ul style="list-style-type: none"> Please ensure the brass washer located under the handle and inside the dome is installed the right way round. Please refer to the instructions Ensure inlet/outlet is correct (follow the arrow)
How often do I need to service my tap	<ul style="list-style-type: none"> Prevent product failure 	<ul style="list-style-type: none"> Service and maintenance of the main operating parts is recommended as this will prolong the life of the product

Water Quality

Maximum chloride Cl- level Guidelines in plumbing systems

	Cold Water	Hot Water
Grade 304L	200	50
Grade 316L	1000	250

When materials may be used in either hot or cold water lines, the guidelines for hot water should be used.

Within these guidelines at ambient temperatures and provided the pH >~6, any negative effect to stainless steel will be unlikely.

Note: Chlorides in water - where the density of the solvent (water) is 1 (which it is to within 0.1% at ambient temperatures), then mg/L = ppm.

For brass products, please ensure the chlorine and chloramines levels are not more than 0.4 ppm.

Please ensure that the water quality supplied to the fixtures meets safe drinking standards to prevent potential staining of the product.

Chlorine guidelines (not to be confused with chloride)

- 316L suitable for chlorine levels up to 5ppm.
- Short term dosing, for example 25-50ppm, for sterilisation purposes of 24-48 hours acceptable if effectively flushed through afterwards.
- Sterilisation is essential during commissioning of potable water systems.

Reference: <https://www.asda.asn.au/component/content/article?id=271:chlorine-and-chloride--same-element,-very-different-effect>

Responsibly Sourced



Reduce Carbon Footprint

GENTEC is rejuvenating the product- no power, less maintenance and longer life.

Rejuvenation Program

To learn more about the rejuvenation program, please contact our customer service at info@gentecaustralia.com.au for more information.

Ethically and Environmentally Sourced

Please refer to GENTEC Business Ethics & Ethical Sourcing Policy at <https://gentecaustralia.com.au/terms-and-conditions/>



A: Unit 6, 20-28 Ricketty St,
Mascot, Sydney, NSW 2020

E: info@gentecaustralia.com.au

P: +612 9319 4422

F: +612 8088 7635

Gentec products come with a Manufacturer's Warranty. To ensure the validity of this warranty, Gentec products must be installed following the provided installation instructions and adhering to AS 3500, NCC Volume Three, relevant Australian Standards, and any local authority requirements applicable to the product. Additionally, water and electrical supply conditions must meet the appropriate national and/or state standards. Non-compliance with these provisions may void the warranty and impact product performance.

Note: The information provided is only a guide, actual product may differ. The information here should not be relied on without clarification with Gentec. Gentec reserves the right to make design changes at any time without notification.

*Subject to terms and conditions. For detailed warranty information, installation compliance, maintenance and cleaning guidelines, and other relevant details, please visit <https://gentecaustralia.com.au>

gentecaustralia.com.au